

ICVC Series

18 SEER Units

Technical Manual

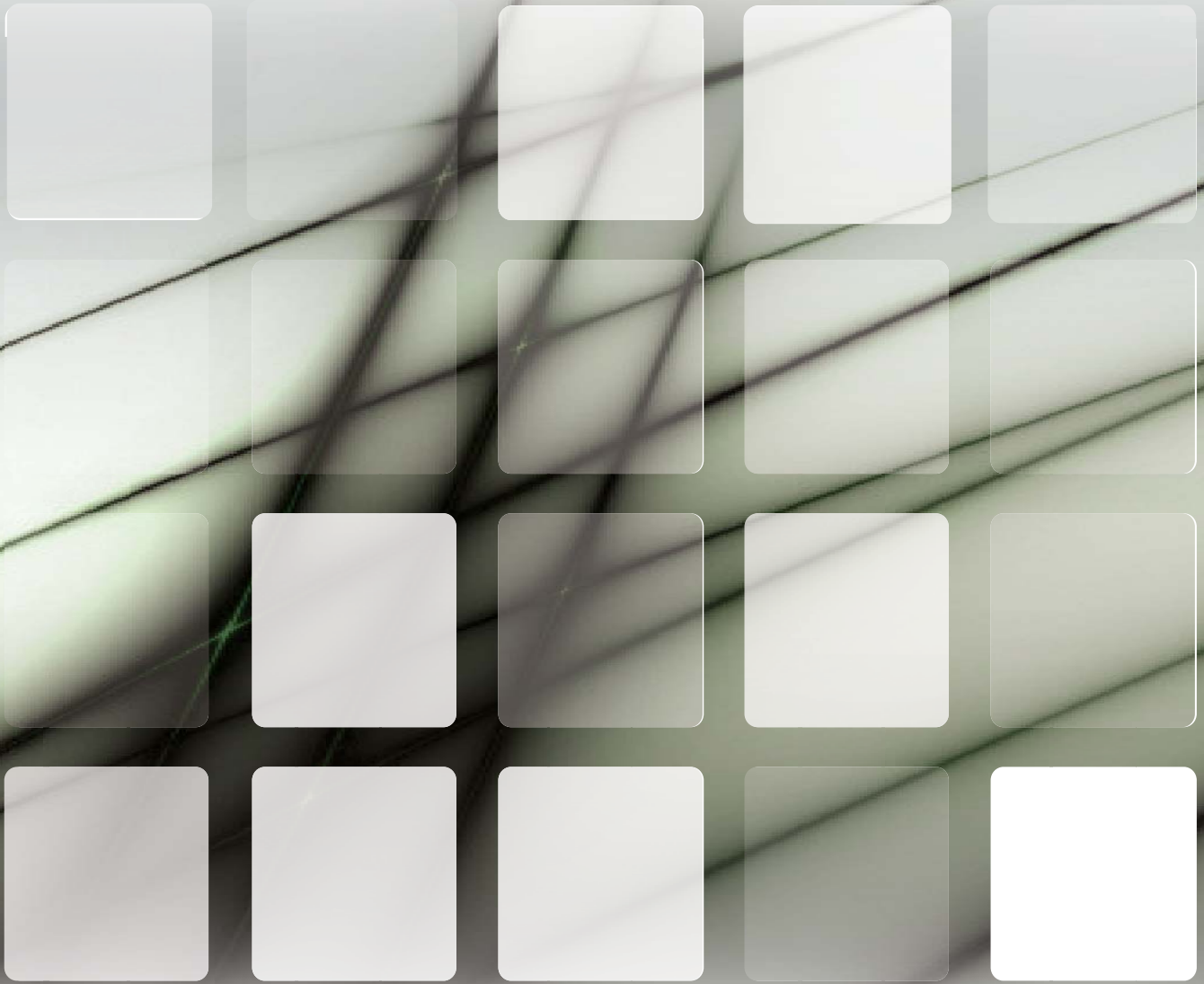

Content

- Part 1. General Information..... 1**
 - 1. Model Names of Indoor/Outdoor Units2
 - 2. External Appearance3
 - 3. Features4
- Part 2. Indoor Unit..... 7**
 - Air Handler Type 7**
 - 1. Features6
 - 2. Specification.....8
 - 3. Dimension10
 - 4. Service Space.....11
 - 5. Wiring Diagrams.....12
 - 6. Electric Characteristics12
 - 7. Exploded View13
 - 8. The Specification of Wiring.....15
 - 9. Field Wiring.....15
- Part 3 Outdoor Unit..... 17**
 - 1. Specification19
 - 2. Dimensions21
 - 3. Service Space.....22
 - 4. Wiring Diagrams23
 - 5. Electric Characteristics23
 - 6. Operation Limits.....25
 - 7. Sound Levels.....26
 - 8. Exploded View.....26
 - 9. Troubleshooting29
- Part 4 Installation 36**
 - 1. Precaution on Installation48
 - 2. Vacuum Dry and Leakage Checking49
 - 3. Additional Refrigerant Charge.....51
 - 4. Insulation Work52
 - 5. Test Operation54

Part 1. General Information

1. Model Names of Indoor/Outdoor Units	2
2. External Appearance.....	3
3. Features	4

1. Model Names of Indoor/Outdoor Units

1.1 Indoor Units

Heat Pump Air Handler

Model name	Dimension(W×H×D) (inch)	Power supply
IEUC824N0A-GNI070A	19.68×45.75×22.05	208~230V-1Ph-60Hz
IEUC836N0A-GNI105A	19.68×45.75×22.05	208~230V-1Ph-60Hz
IEUC848N0A-GNI140A	22.05×53.15×24.53	208~230V-1Ph-60Hz
IEUC860N0A-GNI160A	22.05×53.15×24.53	208~230V-1Ph-60Hz

1.2 Outdoor Units

Cooling Only

Model name	Dimension(W×H×D) (inch)	Power supply
ICVC824N2A-GTI070A	29.13x24.92x29.13	208~230V-1Ph-60Hz
ICVC836N2A-GTI105A	29.13x24.92x29.13	208~230V-1Ph-60Hz
ICVC848N0A-GMI140	29.13x32.87x29.13	208~230V-1Ph-60Hz
ICVC860N0A-GMI160A	29.13x32.87x29.13	208~230V-1Ph-60Hz

Heat Pump

Model name	Dimension(W×H×D) (inch)	Power supply
ICVC824H2A-GTI070A	29.13x24.92x29.13	208~230V-1Ph-60Hz
ICVC836H2A-GTI105A	29.13x24.92x29.13	208~230V-1Ph-60Hz
ICVC848H0A-GMI140A	29.13x32.87x29.13	208~230V-1Ph-60Hz
ICVC860H0A-GMI160A	29.13x32.87x29.13	208~230V-1Ph-60Hz

2.External Appearance

2.1 Indoor unit



2.2 Outdoor unit



3.Features

3.1 Wide operation range.

3.2 Well known brand inverter compressor, reliable quality.

3.3 Condenser coils constructed with copper tubing and enhanced golden fins.

3.4 Use TXV(cooling) as expansion device, and heat pump type with TXV+EXV ;

3.5 DC fan motors, 3-speed, provide selections of air flow to meet desired applications.

3.6 ECM fan motor for air handlers, highrt efficiency, lower noise, constant speed.

3.7 24V control, time delay relay, fan relay and transformer included.

3.8 R410A environment friendly refrigerant.

3.9 AHRI certification, ETL certification.

Part 2. Indoor Unit

Air Handler Type

1. Features	6
2. Specification	8
3. Dimension	10
4. Service Space	11
5. Wiring Diagrams	12
6. Electric Characteristics	12
7. Exploded View	13
8. The Specification of Wiring	15
9. Field Wiring.....	15

1. Features

(1) "A" shape coils, constructed with copper tubing and enhanced aluminum fins

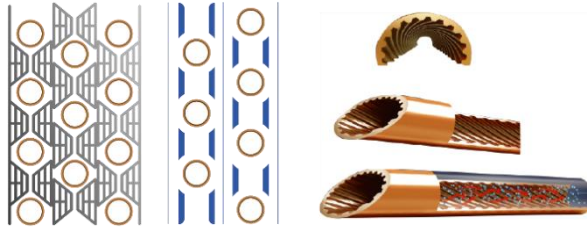

(2) DC fan motors, 3 speed , provides sections of air flow to meet desired applications. Large scroll case, which provides powerful wind., and motor is covered with thermal insulator, keep motor running in safety status.



(4) Use TXV as expansion device (18 SEER air handler)

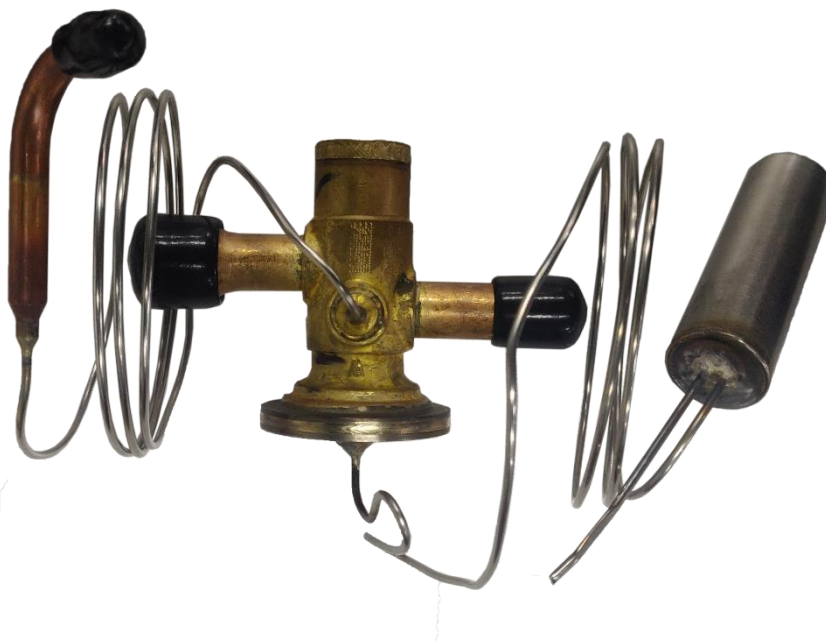

(5) Detachable air filter for cleaning or renewal

Versatile 4-way convertible design for vertical up airflow, horizontal right airflow.

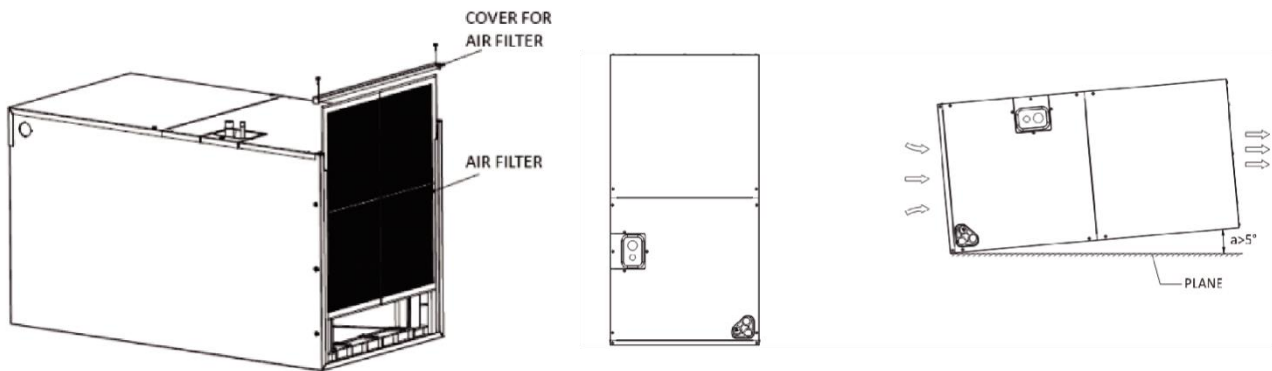

2. Specification

Heat Pump

Model		IEUC824N0A -GNI070A	IEUC836N0A -GNI105A	IEUC848N0A -GNI140A	IEUC860N0A -GNI160A	
Power supply		V/Ph/H z	208-230V/1PH/60Hz			
Cooling	Capacity	Btu/h	24000	34500	47000	56000
	SEER	Btu/h. W	17.5	17.5	17.5	17.5
Heating	Capacity	Btu/h	24000	34500	46500	56000
	HSPF		9.5	9.0	9.5	9.5
Indoor coil	Number of rows		4x2	4x2	5x2	5x2
	Tube outside dia. / Type		7mm / Innergroove tube			
	Fin spacing / Thickness / Type	mm / mm	1.6 / 0.095 / Hydrophilic aluminium			
	Tube pitch(a) x row pitch(b)	mm	13.37 x 21	13.37 x 21	13.37 x 21	13.37 x 21
Indoor motor	type		ECM			
	Rated HP		1/3	1/2	3/4	3/4
	Rated RPM	r/min	1050	1050	1050	1050
	FLA	A	2.8	4.1	6.0	6.0
Indoor fan	material		Galvanized plate			
	Type		Centrifugal			
	Diameter	inch	11	11	11	11
	Height	inch	10-5/8	10-5/8	10-5/8	10-5/8
Indoor air flow		CFM	780	1300	1500	1750
ESP		Pa	25	37.5	50	50
Indoor noise level		dB(A)	63	66	67	68
Metering device	Throttle type		TXV			
Electrical Data	Voltage-Phase-Hz	V-Ph- Hz	208/230V 1Ph 60Hz			
	Minimum Circuit Ampacity	A	1.7	2	5	6
	Max. Overcurrent Protection	A	22	25	30	30
	Min / Max Volts	V	187 / 253	187 / 253	187 / 253	187 / 253
Indoor unit	Dimension (WxHxD)	mm	500x1162x560		560x1350x623	
		in.	19.68x45.75x22.05		22.05x53.15x24.53	
	Packing (WxHxD)	mm	580x1210x650		640x1390x710	
		in.	22.83x47.64x25.59		25.20x54.72x27.95	
	Net / Gross weight	kg	57 / 63	57 / 63	77 / 85	80 / 86
		lbs	126 / 139	126 / 139	170 / 188	176 / 190
Refrigerant piping Liquid side / Gas side		in.	3/8 / 3/4	3/8 / 3/4	3/8 / 7/8	3/8 / 7/8

3. Dimension

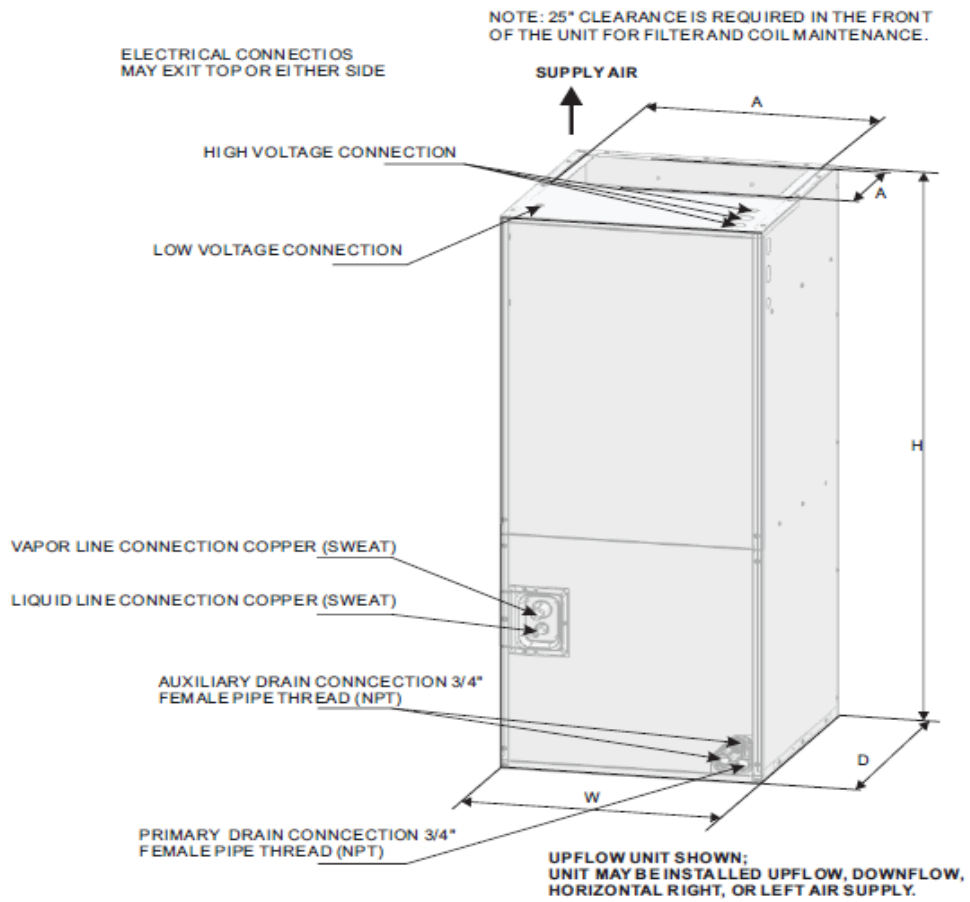

Fig.1 DIMENSIONS

DIMENSIONAL DATA					
MODEL SIZE	Dimensions				
	UNIT HEIGHT "H"/in	UNIT WIDTH "W"/in	UNIT LENGTH "D"/in	SUPPLY DUCT "A"/in	LIQUID LINE / VAPOR LINE IN
24K	45.75	19.68	22.05	454	3/8" / 3/4"
36K	45.75	19.68	22.05	454	3/8" / 3/4"
48K	53.15	22.05	24.53	496	3/8" / 7/8"
60K	53.15	22.05	24.53	496	3/8" / 7/8"

4. Service Space

The indoor unit should be installed in a location that meets the following requirements:
INSTALLATION NOTES: .

1. When up hand discharge , how to trap or plug all drains is see the left Figure.
2. When right hand discharge , how to trap or plug all drains is see the top Figure.
3. The seal-plugs are supplied as accessories , and be screwed tightly only with hand.

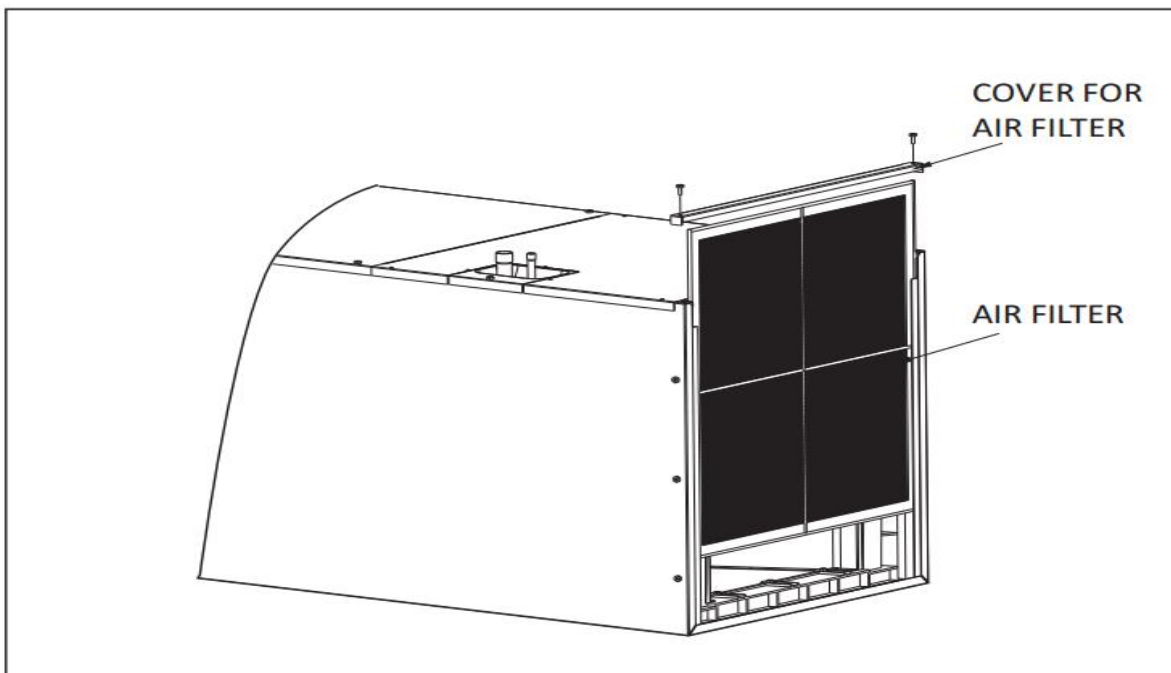
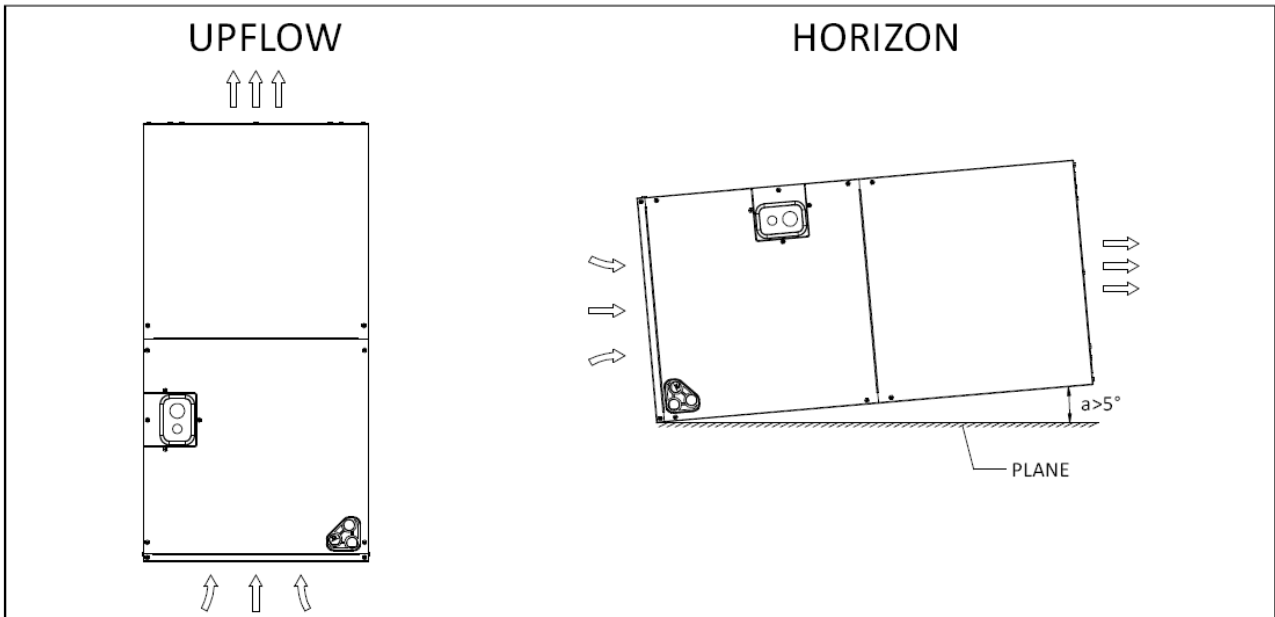

5. Wiring Diagrams

24K/36K/48K/60K

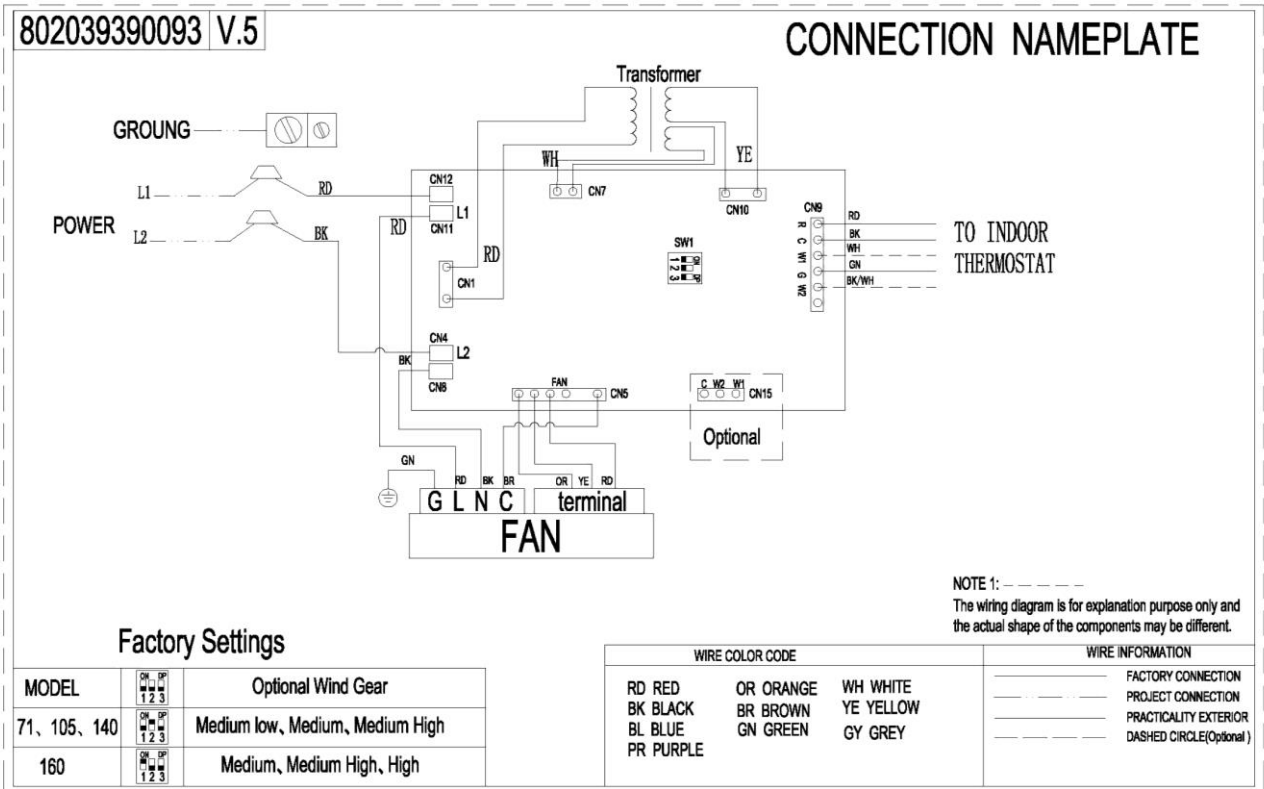

6. Electric Characteristics

Model	Indoor Units			
	Hz	Voltage	Min.	Max.
24K	60	208-230V	187V	253V
36K	60	208-230V	187V	253V
48K	60	208-230V	187V	253V
60K	60	208-230V	187V	253V

7.Exploded View

IEUC824(36,48,60)N0A-GNI070(105,140,170)A

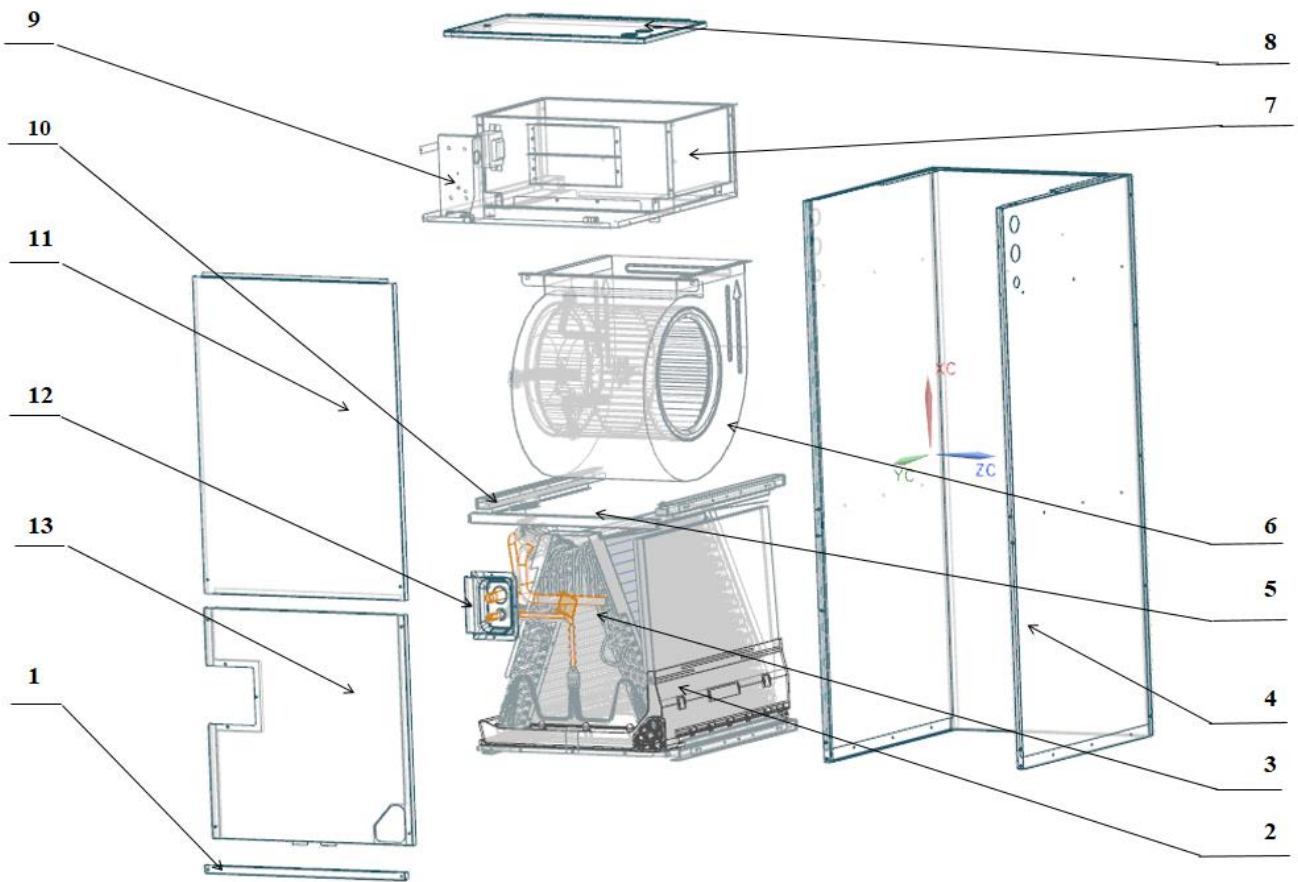

No.	Part Name	Quantity
1	Filter Cover plate	1
2	Water pan components	1
2.1	Water pan# 1	1
2.2	Water pan# 2	1
2.3	Water pan fixed block	1
2.4	Water pan brace	2
3	Evaporator pre-welded assembly	1
3.1	Air header Assembly	1
3.2	Diverter Assembly	1
3.3	TXV	1
3.4	Connecting pipe	1
3.5	Evaporator	2
3.6	Evaporator Baffle	1
3.7	Evaporator baffle welded assembly	1
3.8	Evaporator Water Baffle #1	2
3.9	Evaporator Water Baffle #2	1
3.10	Evaporator Water Baffle #3	1

3.11	Evaporator Fixing Plate #1	1
3.12	Evaporator Fixing Plate #2	1
3.13	Evaporator Junction Plate	1
4	Chassis assembly	1
5	Supporter	2
6.1	Right Volute Wind Wheel	1
6.2	Indoor Motor	1
7	Fan Motor Fixing plate assembly	1
7.1	Fan Motor Fixing plate	1
7.2	Wind Wheel Fixed Block	2
7.3	Fixed plate on air duct	1
7.4	Stator	2
7.5	air duct left stationary plate	1
7.6	air duct right stationary plate	1
8	Electronically Controlled Cover Plate Cotton Pasting Component	1
9	Electronic Control Components	1
9.1	Electronic Control Mounting Plate	1
9.2	Main Board	1
9.3	Transformer	1
10	Water pan supporter assembly	4
11	Upper side plate assembly	1
12	Pipe Cover plate assembly	1
13	Lower side plate assembly	1

8. The Specification of Wiring

Note:

The cross-section areas of wires or lines should not be less than the corresponding ones listed in the table below; Besides, if the power wires is quite long from the unit, please choose the windings with larger cross-section area to guarantee the normal power supply.

Model	Type	Indoor power wire /Diameter (AWG)	Indoor-Outdoor Signal wire /Diameter (AWG)	Thermostat Signal wire /Diameter (AWG)	Outdoor power wire /Diameter (AWG)
24K	Cooling Only	3*16	2*18	4*18	3*14
36K	Cooling Only	3*16	2*18	4*18	3*12
48K	Cooling Only	3*16	2*18	4*18	3*10
60K	Cooling Only	3*16	2*18	4*18	3*10

Model	Type	Indoor power wire /Diameter (AWG)	Indoor-Outdoor Signal wire /Diameter (AWG)	Thermostat Signal wire /Diameter (AWG)	Outdoor power wire /Diameter (AWG)
24K	Heat Pump	3*16	2*18	6*18	3*14
36K	Heat Pump	3*16	2*18	6*18	3*12
48K	Heat Pump	3*16	2*18	6*18	3*10
60K	Heat Pump	3*16	2*18	6*18	3*10

9. Field Wiring

1. To avoid the electrical shock, please connect the air conditioner with the ground lug. The main power plug in the air conditioner has been joined with the ground wiring, please don't change it freely.
2. The power socket is used as the air conditioner specially.
3. Don't pull the power wiring hard.
4. When connecting the air conditioner with the ground, observe the local codes.
5. If necessary, use the power fuse or the circuit, breaker or the corresponding scale ampere.

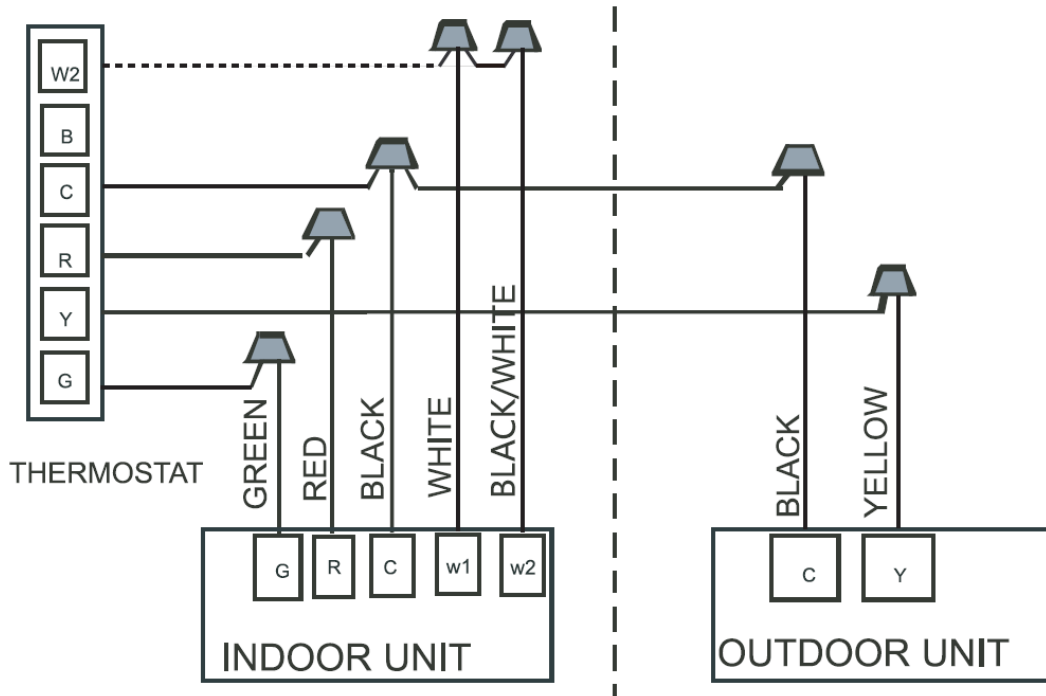

Wiring connection for A/C Systems.

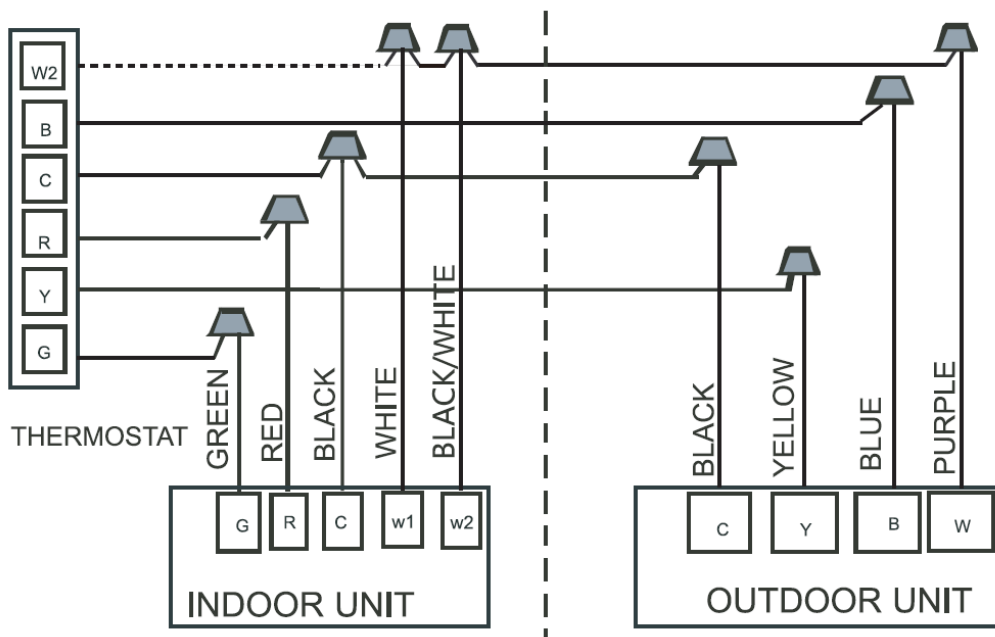

Wiring connection for 18EER H/P Systems.

Part 3 Outdoor Unit

1. Specification	18
2. Dimensions.....	21
3. Service Space	22
4. Wiring Diagrams	23
5. Electric Characteristics	25
6. Operation Limits	25
7. Sound Levels.....	25
8. Exploded View.....	26
9. Troubleshooting	28

1. Specification

Model			ICVC824N2A-GT1070A	ICVC836N2A-GT1105A	ICVC848N0A-GMI140A	ICVC860N0A-GMI160A
Electrical Data	Voltage-Phase-Hz	V-Ph-Hz	208/230V-1Ph-60Hz	208/230V-1Ph-60Hz	208/230V-1Ph-60Hz	208/230V-1Ph-60Hz
	Minimum Circuit Ampacity	A	14	19	25	29
	Max. Overcurrent Protection	A	20	30	40	50
	Min / Max Volts	V	187 / 253	187 / 253	187 / 253	187 / 253
Cooling	Capacity	Btu/h	24000	36000	47000	56000
	EER	Btu/h. W	11.6	11.6	11.6	10.8
	SEER	Btu/W	18	18	18	18
Compressor	Model		ATM240D57U FT	ATM240D57U FT	MNB42FCKM C-L	MNB42FCKMC-L
	Brand		GMCC	GMCC	Mitsubishi	Mitsubishi
	Type		Twin-rotary DC	Twin-rotary DC	Twin-rotary DC	Twin-rotary DC
	Thermal protector	uf	internal	internal	internal	internal
	Rated Capacity	W/h	7190±3%	7190±3%	13780±5%	13780±5%
	Input	W	1935±3%	1935±3%	4040±5%	4040±5%
	Rated inverter input current	A	8.85	8.85	11.80	11.80
	Refrigerant oil	ml	670	670	1400	1400
	RLA	A	10.0	13.9	18.5	22
LRA	A	45	45	58.1	58.1	
Outdoor motor	Model		YDK-110-8P2- AL	YDK-110-8P2- AL	DRN-310-200- 10	DRN-310-200-10
	Brand		Lvzhi	Lvzhi	Panasonic	Panasonic
	Type		AC	AC	DC	DC
	Rated HP	W	110	110	200	200
	Capacitor	µF	6	6	/	/
	Speed	rpm	850/610	850/610	1100	1100
	FLA	A	0.9	0.9	2.5	2.5
Outdoor Fan	material		Metal			
	Type		Axial flow			
	Diameter	In.	23.03	23.03	23.43	23.43
	Height	In.	4.33	4.33	4.53	4.53
	Air flow	CFM	2950	2950	4100	4100
Outdoor coil	Number of row		2	2	2	2
	Tube outside dia	mm (in.)	7 (9/32)	7 (9/32)	7 (9/32)	7 (9/32)
Outdoor noise level		dB(A)	52-63	52-63	54-65	54-65
Outdoor unit	Dimension (W×H×D)	mm	740×633×740		740×835×740	
		inch	29.13x24.92x29.13		29.13x32.87x29.13	
	Packing (W×H×D)	mm	760×660×760		760×875×760	
		in.	30×26×30		30/16×34-4/9×3	
	Net / Gross weight	kg	68 / 72	68 / 72	88 / 93	88 / 93
		lbs	150 / 159	150 / 159	194 / 205	194 / 205
Max. refrigerant pipe length		m	30	30	30	30
		ft	100	100	100	100
Max. difference in level		m	15	15	15	15
		ft	50	50	50	50
Refrigerant system	Liquid side / Gas side	in.	3/8 / 3/4	3/8 / 3/4	3/8 / 7/8	3/8 / 7/8
	Factory charge R410A	oz	114	114	166	166
Operating temperatures		°F	53-118	53-118	53-118	53-118

18 SEER - Technical Manual

Model			ICVC824H2A-GTI070A	ICVC836H2A-GTI105A	ICVC848H0A-GMI140A	ICVC860H0A-GMI160A
Electrical Data	Voltage-Phase-Hz	V-Ph-Hz	208/230V-1Ph-60Hz			
	Circuit Ampacity Max.	A	14	19	25	29
	Overcurrent Protection	A	20	30	40	50
	Min / Max Volts	V	187 / 253	187 / 253	187 / 253	187 / 253
Cooling	Capacity	Btu/h	24000	34500	47000	56000
	EER	Btu/h.W	11.6	11.6	11.6	10.8
	SEER	Btu/h.W	17.5	17.5	17.5	17.5
Heating	Capacity	Btu/h	24000	34500	46500	55000
	HSPF	Btu/h.W	9.5	9.0	9.5	9.5
Compressor	Model		ATM240D57UF T	ATM240D57UF T	MNB42FCKMC- L	MNB42FCKM C-L
	Brand		GMCC	GMCC	Mitsubishi	Mitsubishi
	Type		Twin-rotary DC	Twin-rotary DC	Twin-rotary DC	Twin-rotary DC
	Thermal protector	uf	internal	internal	internal	internal
	Rated Capacity	W/h	7190±3%	7190±3%	13780±5%	13780±5%
	Input	W	1935±3%	1935±3%	4040±5%	4040±5%
	Rated inverter input current	A	8.85	8.85	11.80	11.80
	Refrigerant oil	ml	670	670	1400	1400
	RLA		13.5	18.5	27.2	27.2
LRA		45	45	58.1	58.1	
Outdoor motor	Model		YDK-110-8P2- AL	YDK-110-8P2- AL	DRN-310-200- 10	DRN-310-200- 10
	Brand		Lvzhi	Lvzhi	Panasonic	Panasonic
	Type		AC	AC	DC	DC
	Rated output power	W	110	110	200	200
	Capacitor	µF	6	6	/	/
	Speed	rpm	850/610	850/610	1100	1100
	FLA	A	0.9	0.9	2.5	2.5
Outdoor Fan	Material		Metal			
	Type		Axial flow			
	Diameter	In.	23.03	23.03	23.43	23.43
	Height	In.	4.33	4.33	4.53	4.53
	Air flow	CFM	2400	2950	4100	4100
Outdoor coil	Number of row		1	2	2	2
	Tube outside dia	mm (in.)	7 (9/32)	7 (9/32)	7 (9/32)	7 (9/32)
Outdoor coil		dB(A)	52-63	52-63	54-65	54-65
Outdoor unit	Dimension (W×H×D)		740×633×740		740×835×740	
			29.13×24.92×29.13		29.13×32.87×29.13	
	Packing (W×H×D)		760×660×760		760×875×760	
			30×26×30		30/16×34-4/9×3	
	Net / Gross weight		71 / 75	71 / 75	91 / 96	91 / 96
Refrigerant type			R410A	R410A	R410A	R410A
Refrigerant quantity		kg	3.35	3.35	4.85	4.85
Refrigerant system	Liquid side / Gas side	in.	3/8 / 3/4	3/8 / 3/4	3/8 / 7/8	3/8 / 7/8
	Factory charge R410A	oz	114	114	166	166
	Metering device		EEV	EEV	EEV	EEV
Max. refrigerant pipe length			30	30	30	30
			100	100	100	100
Max. difference in level			15	15	15	15
			50	50	50	50
Operating temperatures		°F	5-118	5-118	5-118	5-118

2.Dimensions

All dimensions are in mm. They are subject to change without notice. Certified dimensions will be provided upon request.

Unit Model	Dimensions(mm)			Refrigerant Connection Line Size(mm)			
	A	B	C	Liquid(Φ)		Vapor(Φ)	
				LF	RF	LF	RF
24	633	740	740	9.52		19.05	
36	633	740	740				
48	843	740	740				
60	843	740	740		22		

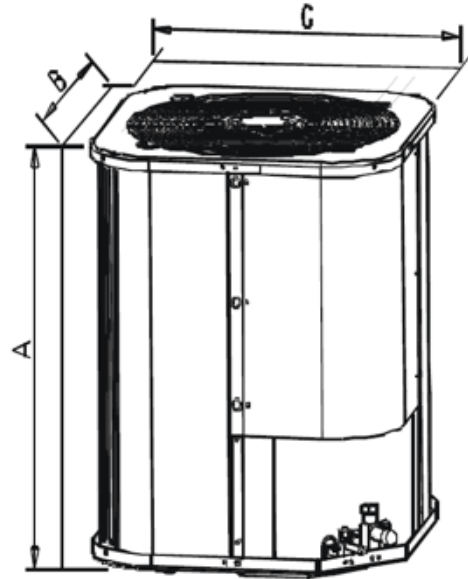

NOTE: LF means cooling only model; RF means heat pump model.

3. Service Space

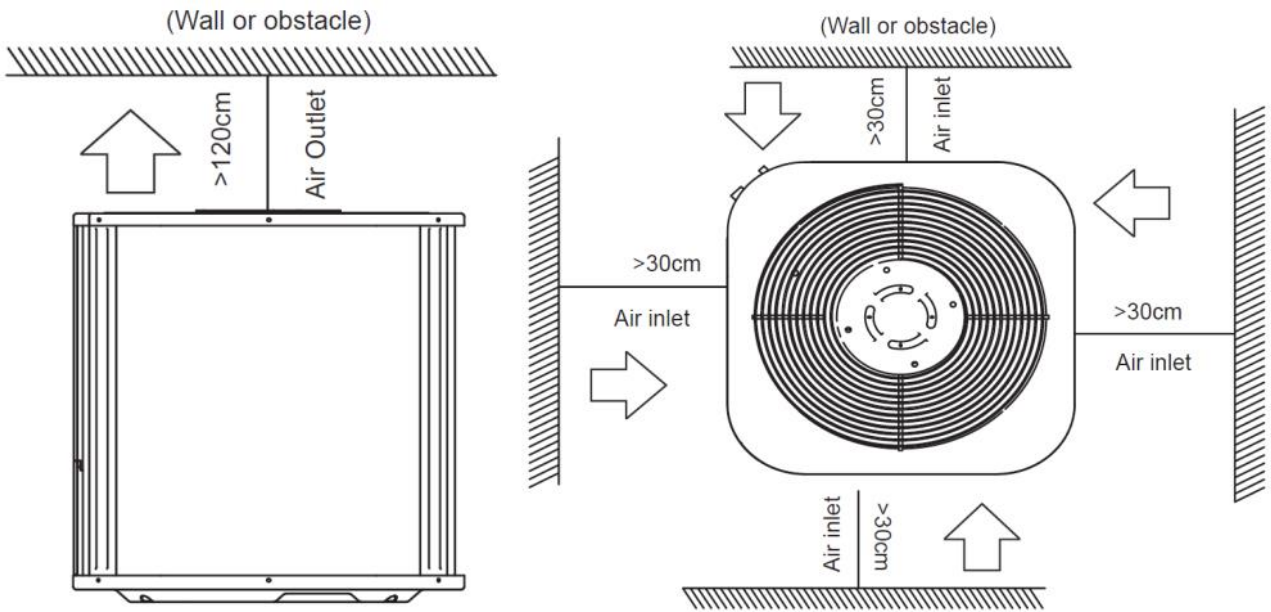

TYPICAL INSTALLATION

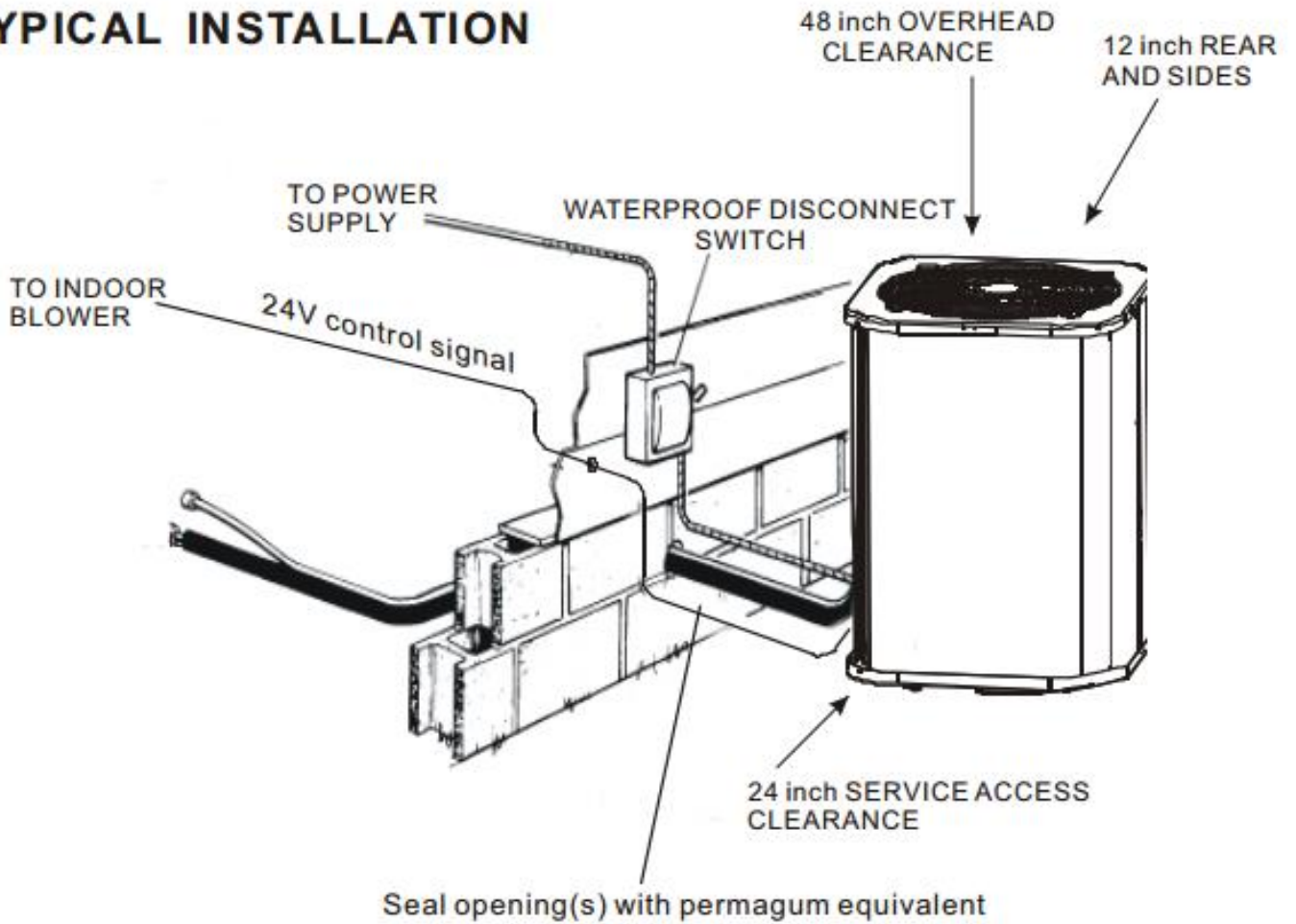

4. Wiring Diagrams

SEER 18 Cooling only

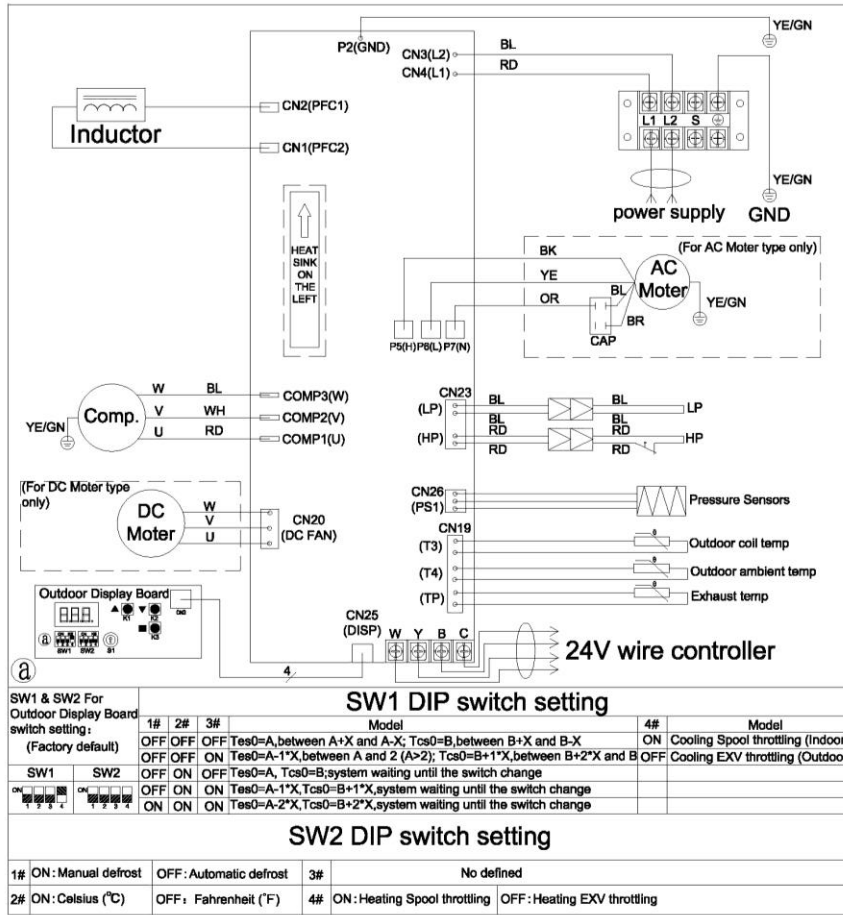

Check Table

NUM	Display content	16	Frequency increase (Shift ; Actual value)
01	Outdoor power(Model)	17	ΔEV (step ; Actual value)
02	Run mode (0: Standby mode; 2:In cooling mode; 3: In heating mode)	18	- - -
03	Arget frequency (Hz ; Actual value)	19	IPM modular temp Tfin (°F ; Actual value)
04	Running frequency (Hz ; Actual value)	20	Oil output (CC ; Actual value / 8)
05	Actual frequency (Hz ; Actual value)	21	Target temp Tes/Tcs (°F ; Actual value)
06	Fan speed (High / low ; Actual value)	22	Pressure value (PSI ; Actual value * 25)
07	Temp transform by pressure sensor (°F;Actual value)	23	Pressure valve transform by T3 (PSI ; Actual value * 25)
08	T3 condensing temp (°F ; Actual value)	24	- - -
09	T4 outdoor ambient temp (°F ; Actual value)	25	Target superheat (°F ; Actual value)
10	T5 exhaust temp (°F ; Actual value)	26	Discharge temp superheat (°F ; Actual value)
11	AC current (A ; Actual value)	28	Ability test mode (1-40 ; Mode gear)
12	Compressor current	29	Software version number (1-255)
13	AC voltage (VAC ; Actual value * 2)	31	Enter PI contrio sign (0 or 1)
14	DC voltage (VDC ; Actual value / 2)	34	Frequency limit item
15	EXV opening degree (step ; Actual value / 4)	37	Last failure or protection code

Failure and Protection

Code	Failure or protection definition	Code	Failure or protection definition
E4	T4 outdoor air temperature sensor fault	P4	Exhaust overheating protection
E6	T3 Condensate temperature sensor failure	P5	T3 condenser sensor high temp protection(In cooling mode)
E5	T5 Exhaust temperature sensor fault	P6	IPM protection
E9	AC overvoltage/undervoltage protection	P8	IPM high temperature protection (Ft)
E10	EEPROM failure	P9	DC fan motor error
E12	IPM modular sensor error	P12	Wet operation error
E13	Pressure sensor error	P13	High pressure abnormal error(In heating mode)
E14	T3 or T5 sensor disconnect error	P14	High compression ratio protection
E15	High pressure switch error	P15	Low compression ratio protection
H0	Communication fault of master board and driver chip	L1	DC cable bus low voltage protection
H1	T3 sensor high temperature error(In cooling mode) (20 times P5 error within 180mins)	L2	DC cable bus high voltage protection
H2	High pressure switch error(20 times P1 error within 150 mins)	L4	MCE fault / sync / closed loop
H3	High pressure abnormal in heating mode (20 times P13 error within 180 mins)	L5	Zero speed protection
H4	IPM modular high temp error (20 times P8 within 120 mins)	L7	Compressor phase loss protection ratio protection
H5	Low pressure error (20 times P2 within 100 mins)	L8	Compressor stalls
H6	Discharge temperature abnormal error(20 times P4 within 100 mins)	L9	Frequency limitation or decline by high pressure
H7	Wet operation error (20 times P12 within 200 mins)	LA	Frequency limitation by voltage
H8	T3 condenser sensor disconnect error (20 times E14 within 100 mins)	LC	Frequency limitation by condenser temp
H12	Discharge temp sensor disconnect error(20 times E14 within 180 mins)	LD	Frequency limitation by discharge temp
P1	High pressure protection	LE	Frequency limitation by IPM modular high temp
P2	Low pressure protection	LF	Frequency limitation by current
P3	inverter overcurrent protection	d0	Oil return
		dF	Defrost
		dH	Force cooling

SEER 18 Heat Pump

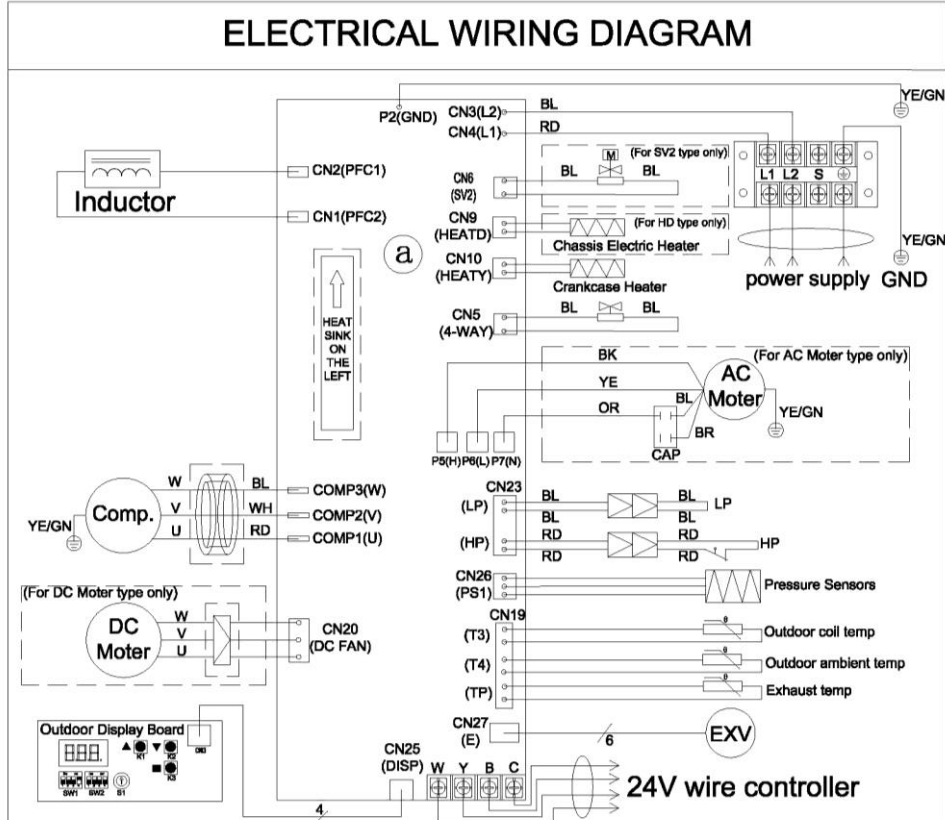

SW1 & SW2 For Outdoor Display Board switch setting:
(Factory default)

SW1 DIP switch setting			
1#	2#	3#	Model
OFF	OFF	OFF	Tes0=A,between A+X and A-X; Tcs0=B,between B+X and B-X
OFF	OFF	ON	Tes0=A-1*X,between A and 2 (A>2); Tcs0=B+1*X,between B+2*X and B
OFF	ON	OFF	Tes0=A, Tcs0=B;system waiting until the switch change
OFF	ON	ON	Tes0=A-1*X,Tcs0=B+1*X,system waiting until the switch change
ON	ON	ON	Tes0=A-2*X,Tcs0=B+2*X,system waiting until the switch change

SW2 DIP switch setting			
1#	2#	3#	4#
ON	ON	Manual defrost	OFF: Automatic defrost
ON	ON	Celsius (°C)	OFF: Fahrenheit (°F)
			3# No defined
			4# ON: Heating Spool throttling OFF: Heating EXV throttling

Check Table		
NUM	Display content	
01	Outdoor power(Model)	16 Frequency increase (Shift ; Actual value)
02	Run mode (0: Standby mode; 2:In cooling mode ; 3: In heating mode)	17 ΔEV (step ; Actual value)
03	Arget frequency (Hz ; Actual value)	18 ---
04	Running frequency (Hz ; Actual value)	19 IPM modular temp Tfin (°F ; Actual value)
05	Actual frequency (Hz ; Actual value)	20 Oil output (CC ; Actual value / 8)
06	Fan speed (High / low ; Actual value)	21 Target temp Tes/Tcs (°F ; Actual value)
07	Temp transform by pressure sensor (°F ; Actual value)	22 Pressure value (PSI ; Actual value * 25)
08	T3 condensing temp (°F ; Actual value)	23 Pressure valve transform by T3 (PSI ; Actual value * 25)
09	T4 outdoor ambient temp (°F ; Actual value)	24 ---
10	T5 exhaust temp (°F ; Actual value)	25 Target superheat (°F ; Actual value)
11	AC current (A ; Actual value)	26 Discharge temp superheat (°F ; Actual value)
12	Compressor current	28 Ability test mode (1-40 ; Mode gear)
13	AC voltage (VAC ; Actual value * 2)	29 Software version number (1-255)
14	DC voltage (VDC ; Actual value / 2)	31 Enter PI conrtio sign (0 or 1)
15	EXV opening degree (step ; Actual value / 4)	34 Frequency limit item
		37 Last failure or protection code
Failure and Protection		
Code	Failure or protection definition	Code
E4	T4 outdoor air temperature sensor fault	P4 Exhaust overheating protection
E6	T3 Condensate temperature sensor failure	P5 T3 condenser sensor high temp protection(In cooling mode)
E5	T5 Exhaust temperature sensor fault	P6 IPM protection
E9	AC overvoltage/undervoltage protection	P8 IPM high temperature protection (Ft)
E10	EEPROM failure	P9 DC fan motor error
E12	IPM modular sensor error	P12 Wet operation error
E13	Pressure sensor error	P13 High pressure abnormal error(In heating mode)
E14	T3 or T5 sensor disconnect error	P14 High compression ratio protection
E15	High pressure switch error	P15 Low compression ratio protection
H0	Communication fault of master board and driver chip	L1 DC cable bus low voltage protection
H1	T3 sensor high temperature error(In cooling mode) (20 times P5 error within 180mins)	L2 DC cable bus high voltage protection
H2	High pressure switch error(20 times P1 error within 150 mins)	L4 MCE fault / sync / closed loop
H3	High pressure abnormal in heating mode (20 times P13 error within 180 mins)	L5 Zero speed protection
H4	IPM modular high temp error (20 times P8 within 120 mins)	L7 Compressor phase loss protection ratio protection
H5	Low pressure error (20 times P2 within 100 mins)	L8 Compressor stalls
H6	Discharge temperature abnormal error(20 times P4 within 100 mins)	L9 Frequency limitation or decline by high pressure
H7	Wet operation error (20 times P12 within 200 mins)	LA Frequency limitation by voltage
H8	T3 condenser sensor disconnect error (20 times E14 within 100 mins)	LC Frequency limitation by condenser temp
H12	Discharge temp sensor disconnect error(20 times E14 within 180 mins)	LD Frequency limitation by discharge temp
P1	High pressure protection	LE Frequency limitation by IPM modular high temp
P2	Low pressure protection	LF Frequency limitation by current
P3	inverter overcurrent protection	d0 Oil return
		dF Defrost
		dH Force cooling

5. Electric Characteristics

Model	Outdoor Unit			
	Hz	Voltage	Min.	Max.
ICVC824N2A-GTI070A	60	208~230V	187V	253V
ICVC836N2A-GTI105A	60	208~230V	187V	253V
ICVC848N0A-GMI140A	60	208~230V	187V	253V
ICVC860N0A-GMI160A	60	208~230V	187V	253V

6. Operation Limits

Operation mode	Outdoor temperature(°C)	Room temperature(°C)
Cooling operation	10~48	≥16

7. Sound Levels

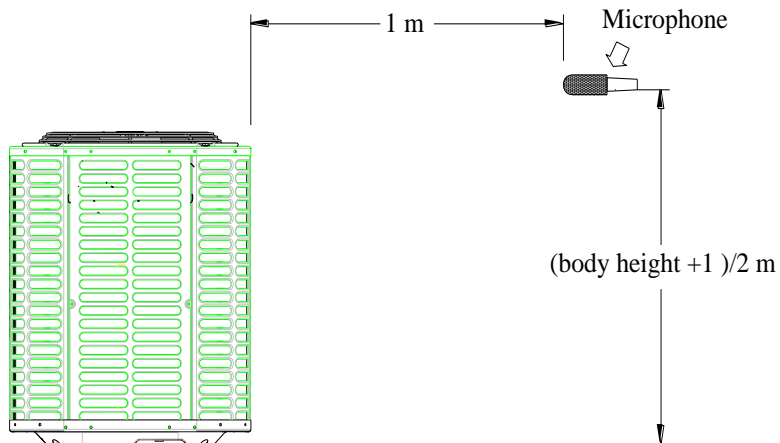

Model	Noise level dB(A)
ICVC824N2A-GTI070A	52-63
ICVC836N2A-GTI105A	52-63
ICVC848N0A-GMI140A	54-65
ICVC860N0A-GMI160A	54-65

Note: Sound level is measured at a point 1 m in front of the unit, at a height of $(\text{Unit body height} + 1) / 2$ m.

8. Exploded View

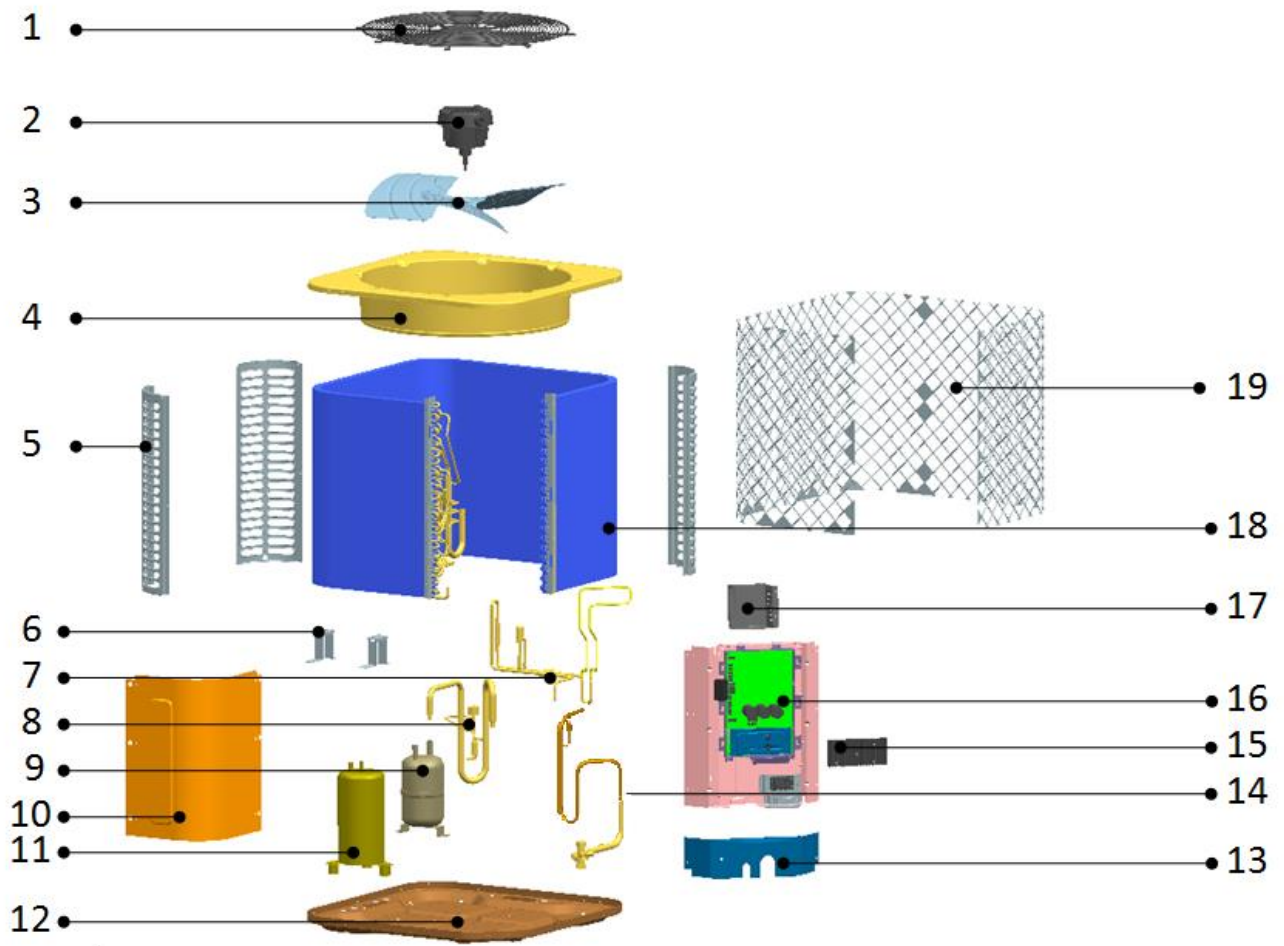

No.	Part Name	Quantity
1	Cover net	1
2	Outdoor motor	1
3	Axial-flow fan	1
4	Top cover assembly	1
5	Support board	3
6	Piping support plate	2
7	Refrigerant radiating pipe component	1
8	Air return duct welding assembly	1
8.1	Solenoid Valve	1
8.2	Air return duct #1	1
8.3	Air return duct #2	1
8.4	Liquid bypass capillary assembly	1
8.5	Solenoid Valve coil	1
9	Gas-liquid separator	1
10	Top panel	1
11	Inverter Compressor	1
12	Chassis assembly	1
13	Left side panel	1
14	Pipeline component	1
14.1	High pressure valve welding assembly	1
14.1.1	High pressure valve connecting pipe	1
14.1.2	Service valve	1
15	Radiator cover	1
16	Electronic components	1
16.1	Terminal	1
16.2	Outdoor display panel	1
16.3	Outdoor inverter integrated board	1
16.4	Reactor	1
16.5	Fan capacitor	1
16.6	Electronic controlled mounting plate welding parts	1
16.7	Mainboard mounting base	1
16.8	Communication board mounting base	1
16.9	Terminal mounting plate	1
17	Reactor mounting plate	1
18	Condenser unit	1
19	Top discharge outdoor unit protective net	1

9. Troubleshooting

9.1. Control logic description

1. Display board button function

▲ button: check button、setting button“+”

▼ button: check button、setting button“-”

■ button:

A、Short press: force cooling mode, display board will show “dH”;

B、Long press: entering test mode, and you can change unit parameter manually:

When it show “Sc.”, then you can set Compressor Frequency manually, using “▲” and “▼”to change frequency.

Then press “■” button, display board will show “SF.”, then you can set fan speed manually, using “▲” and “▼”to

change fan speed.

Then press “■” button, display board will show “SL.”, then you can set expansion valve open degree manually, using

“▲” and “▼”to change expansion valve opening degree.

Then press “■” button, display board will show “SP.”, then you can set PFC switch manually, (0 means OFF, 1

means ON), using “▲” and “▼” to set PFC switch ;

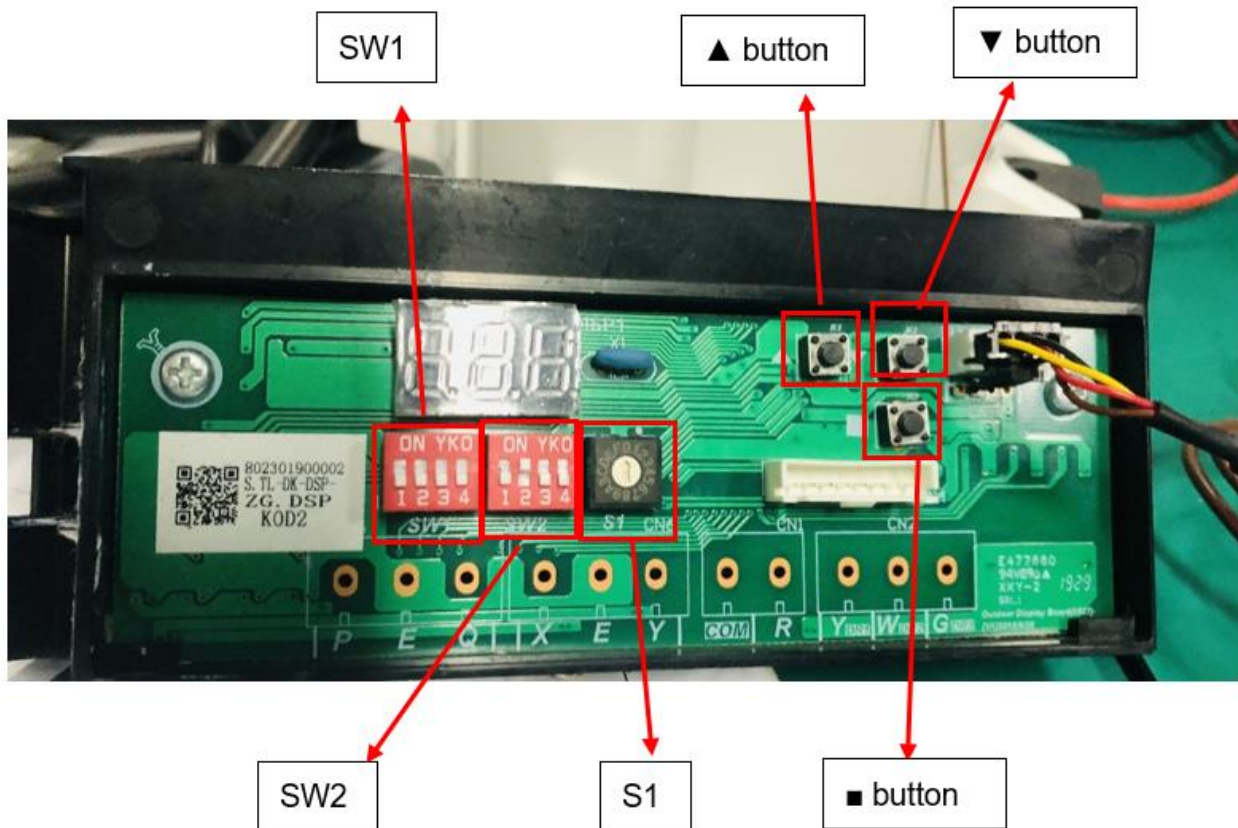

SW1:

1st bit	2nd bit	3rd bit	4th bit
Outdoor unit control logic(target evaporator temperature and target condensation temperature) setting, manufacture only.			ON: EXV throttling in cooling mode OFF: Piston throttling in cooling mode The function will be active after unit power off and power on.

SW2:

1st bit	2nd bit	3rd bit	4th bit
ON: Manually defrost. OFF: Automatic defrost The function will be active immediately after bit change.	ON: Display as Fahrenheit OFF: Display as Celsius The function will be active after unit power off and power on.	Reserved	ON: EXV throttling in heating mode OFF: Piston throttling in heating mode The function will be active after unit power off and power on.

S1: Reserved

9.2 Parameter point check table

1). Top discharge outdoor unit

For 24/36K model

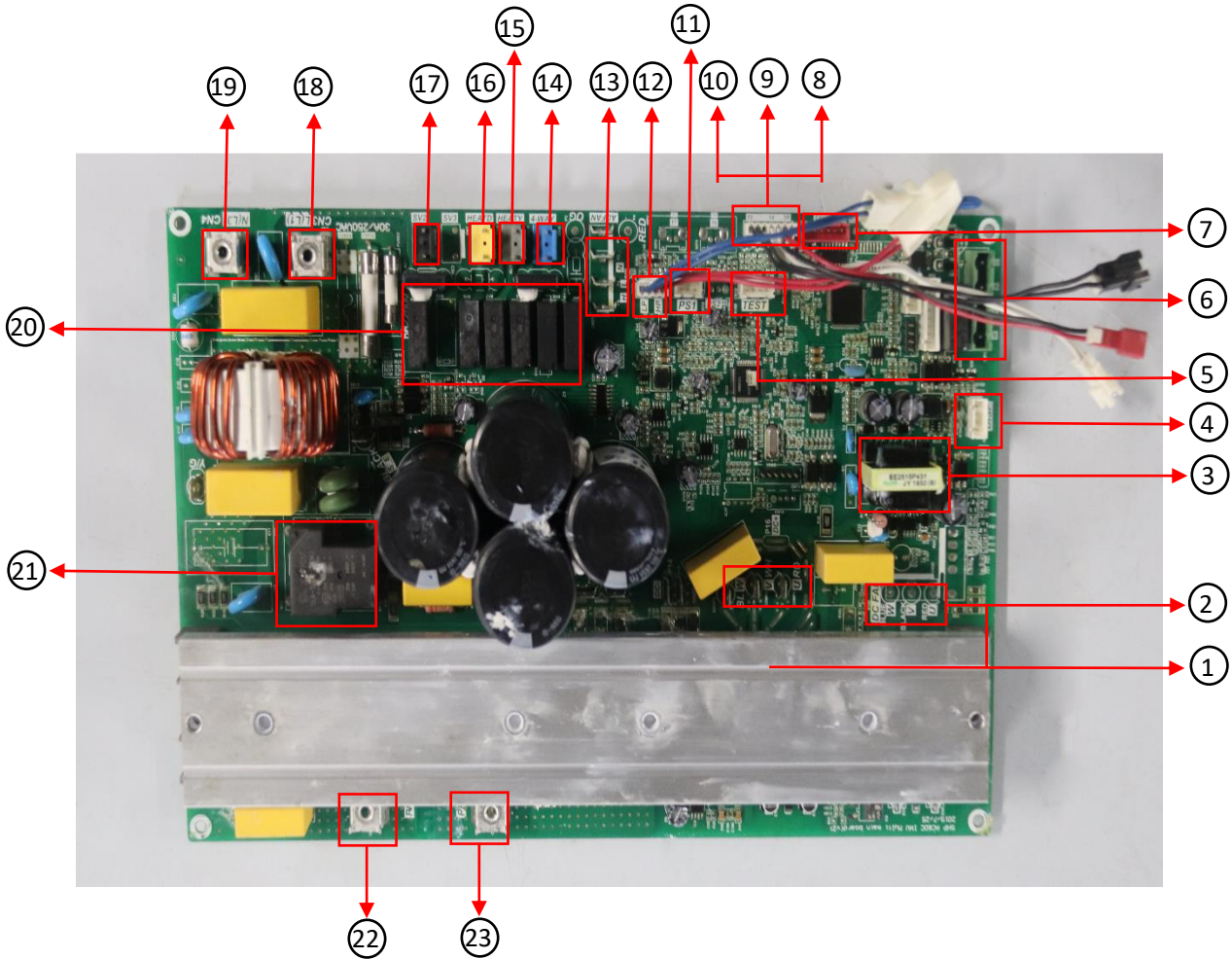

Function description for the corresponding position:

No.	Content	No.	Content
1	Compressor wiring terminal	12	High/Low pressure switch ports
2	DC fan motor wiring terminal	13	AC fan motor wiring terminal
3	Transformer	14	Four-way valve control port
4	Outdoor display board wiring terminal	15	Crankcase Heating zone control terminal
5	Reserved	16	Chassis Electric Heater control terminal
6	24V wire controller interface	17	Solenoid valve2 control terminal
7	EXV drive port	18	Power supply connecting terminal
8	Exhaust temperature sensor port(T5)	19	Power supply connecting terminal
9	Outdoor ambient temperature sensor port(T4)	20/21	Relay
10	Condenser temperature sensor port(T3)	22	Inductor wiring terminal 1
11	Pressure sensors ports	23	Inductor wiring terminal 2

For 48/60K model

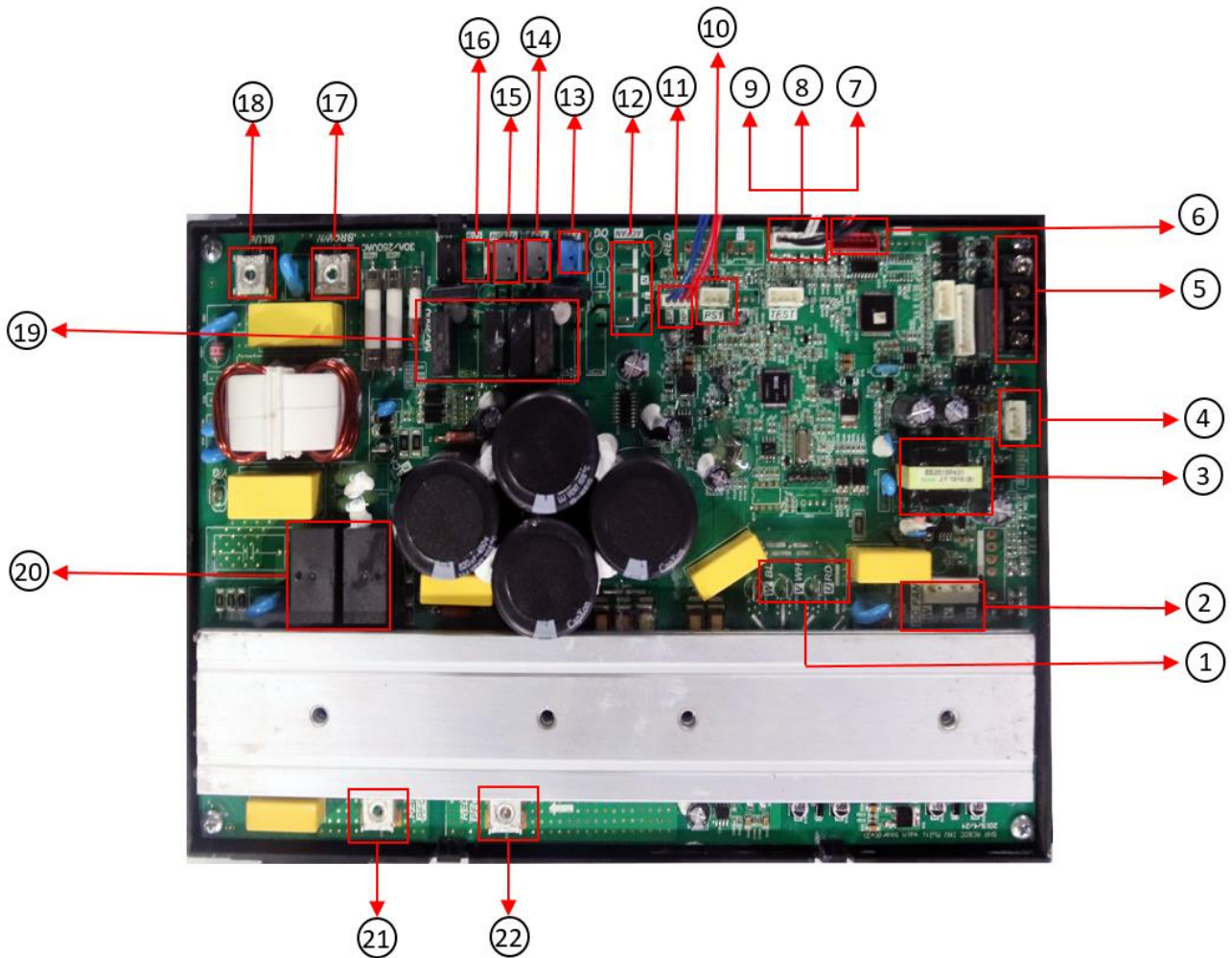

Function description for the corresponding position:

No.	Content	No.	Content
1	Compressor wiring terminal	12	AC fan motor wiring terminal
2	DC fan motor wiring terminal	13	Four-way valve control port
3	Transformer	14	Crankcase Heating zone control terminal
4	Outdoor display board wiring terminal	15	Chassis Electric Heater control terminal
5	24V wire controller interface	16	Solenoid valve control terminal
6	EXV drive port	17	Power supply connecting terminal
7	Exhaust temperature sensor port(T5)	18	Power supply connecting terminal
8	Outdoor ambient temperature sensor port(T4)	19	Relay
9	Condenser temperature sensor port(T3)	20	Relay
10	Pressure sensors ports	21	Inductor wiring terminal 1
11	High/Low pressure switch ports	22	Inductor wiring terminal 2

2).Air handing unit

For 24/36K/48/60 model

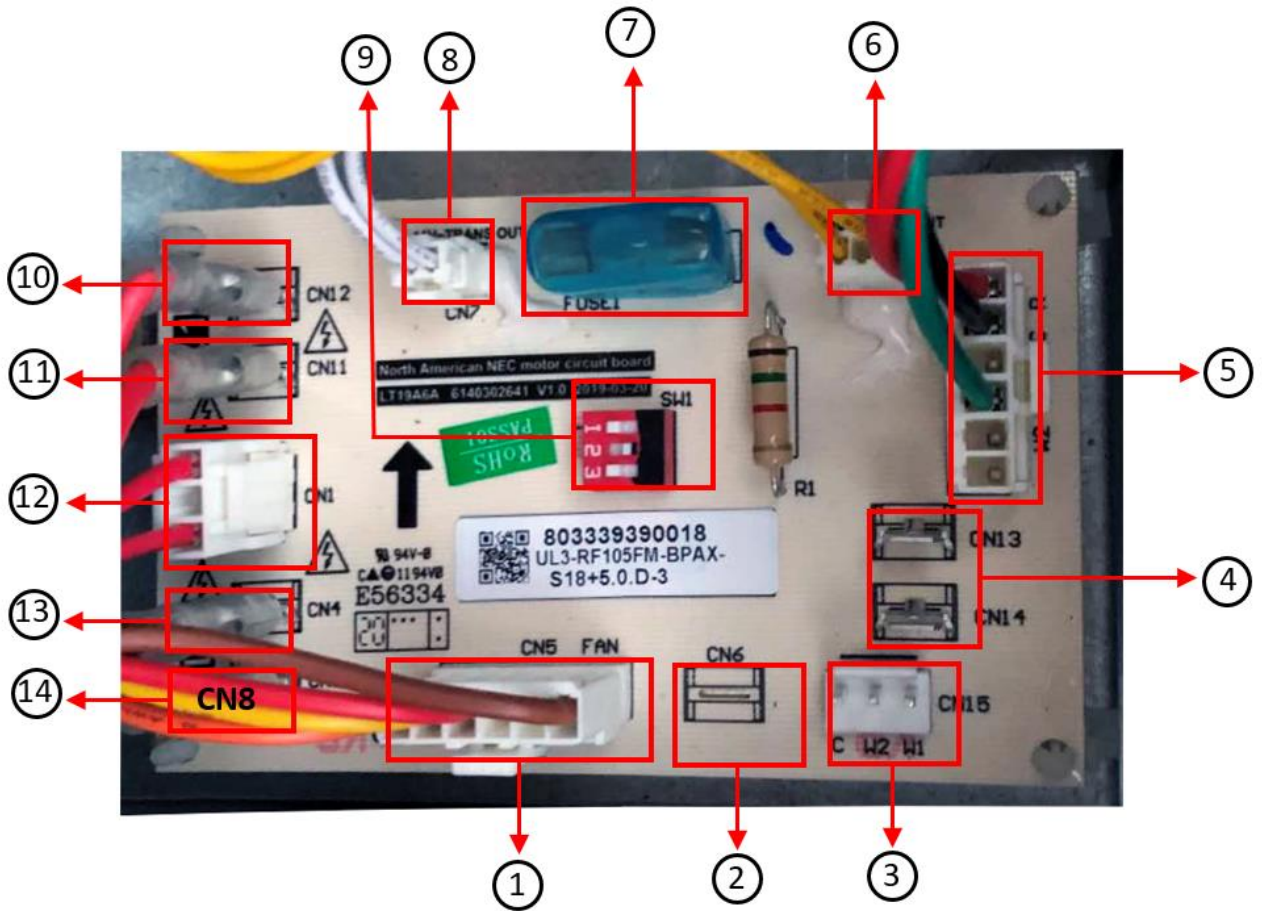

Function description for the corresponding position:

No.	Content	No.	Content
1	DC fan motor wiring terminal	8	Output port of transformer(11V)
2	Reserved	9	Dip switch to adjust fan speed
3	Chassis Electric Heater control terminal	10	Power supply connecting terminal(L1)
4	Reserved	11	Fan power cord input port(L1)
5	24V wire controller interface	12	Input power cord transformer port
6	Output port of transformer(24V)	13	Power supply connecting terminal(L2)
7	Fuse	14	Fan power cord input port(L2)

9.3 Error codes

The fault codes for outdoor unit as follows:

CODE	FAULT DESCRIPTION
E4	T4 Outdoor ambient temperature sensor error
E5	T5 Discharge temperature sensor error
E6	T3 Condenser temperature sensor error
E9	AC under voltage protection
E10	EEPROM error
E12	IPM modular sensor error
E13	HLP Pressure sensor error
E14	T3 or T5 sensor disconnect error
E15	High pressure switch error
H0	Communication error of main chip and IPM chip
H1	T3 sensor high temperature error(In cooling mode) (20 times P5 error within 180mins)
H2	High pressure switch error(20 times P1 error within 150 mins)
H3	High pressure abnormal in heating mode (20 times P13 error within 180 mins)
H4	IPM modular high temp error (20 times P8 within 120 mins)
H5	Low pressure error (20 times P2 within 100 mins)
H6	Discharge temperature abnormal error(20 times P4 within 100 mins)
H7	Wet operation error (20 times P12 within 200 mins)
H8	T3 condenser sensor disconnect error (20 times E14 within 100 mins)
H12	Discharge temp sensor disconnect error(20 times E14 within 180 mins)
P1	High pressure protection
P2	Low pressure protection
P3	DC over current protection
P4	T5 Discharge temperature abnormal error
P5	T3 Condenser sensor high temp protection(In cooling mode)
P6	IPM module protection
P8	IPM high temperature protection (Ft)M high temperature protection (Ft)
P9	DC fan motor error
P12	Wet operation error
P13	High pressure abnormal error(In heating mode)
P14	High compression ratio protection
P15	Low compression ratio protection
L1	DC cable bus low voltage protection

L2	DC cable bus high voltage protection
L4	MCE fault / sync / closed loop
L5	Zero speed protection
L7	Compressor phase loss protection ratio protection
L8	Compressor stalls
L9	Frequency limitation or decline by high pressure
LA	Frequency limitation by voltage
LC	Frequency limitation by condenser temp.
LD	Frequency limitation by discharge temp
LE	Frequency limitation by IPM modular high temp
LF	Frequency limitation by current
d0	Oil return
dF	Defrost
dH	Force cooling

9.4 Troubleshooting guidelines

E4/E5/E6 (T4/T5/T3 temperature sensors error)

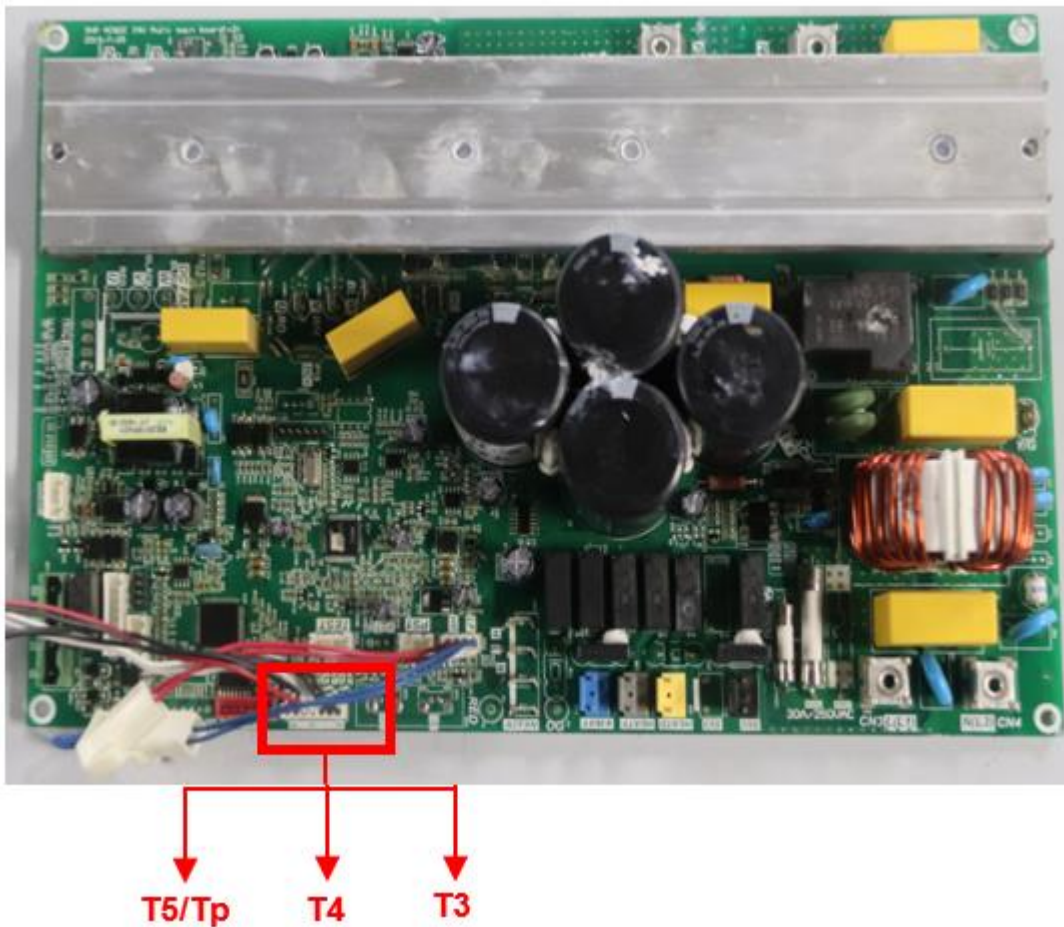
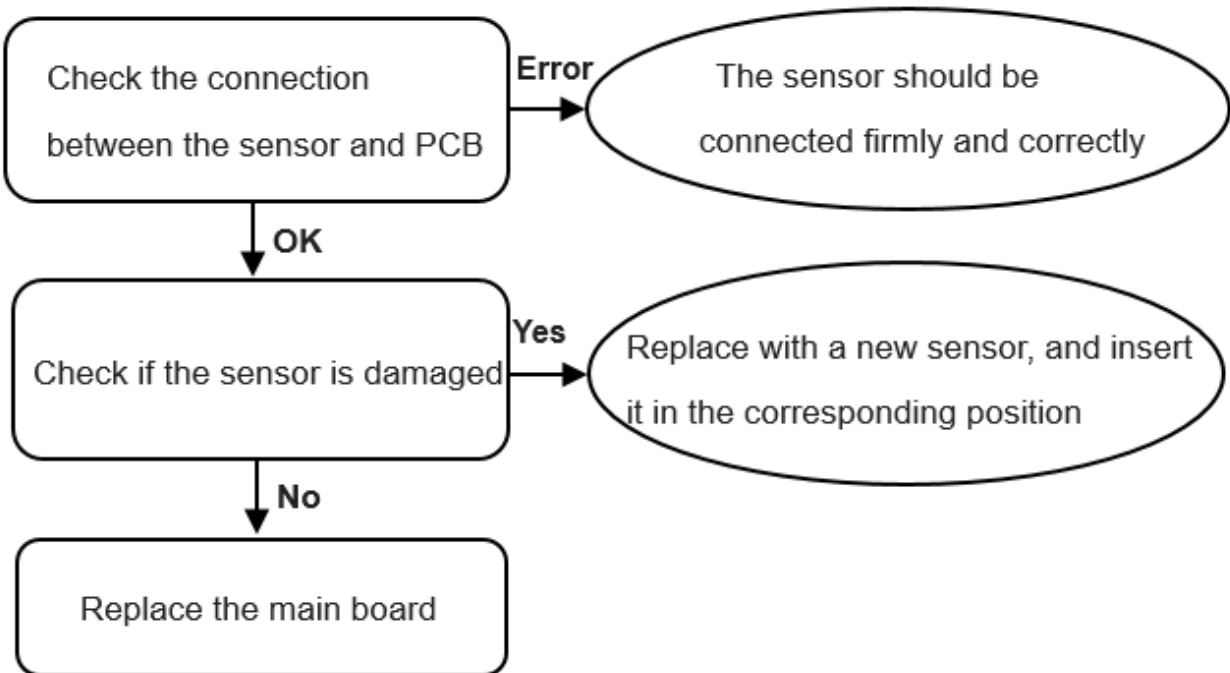

E9 (AC under voltage protection)

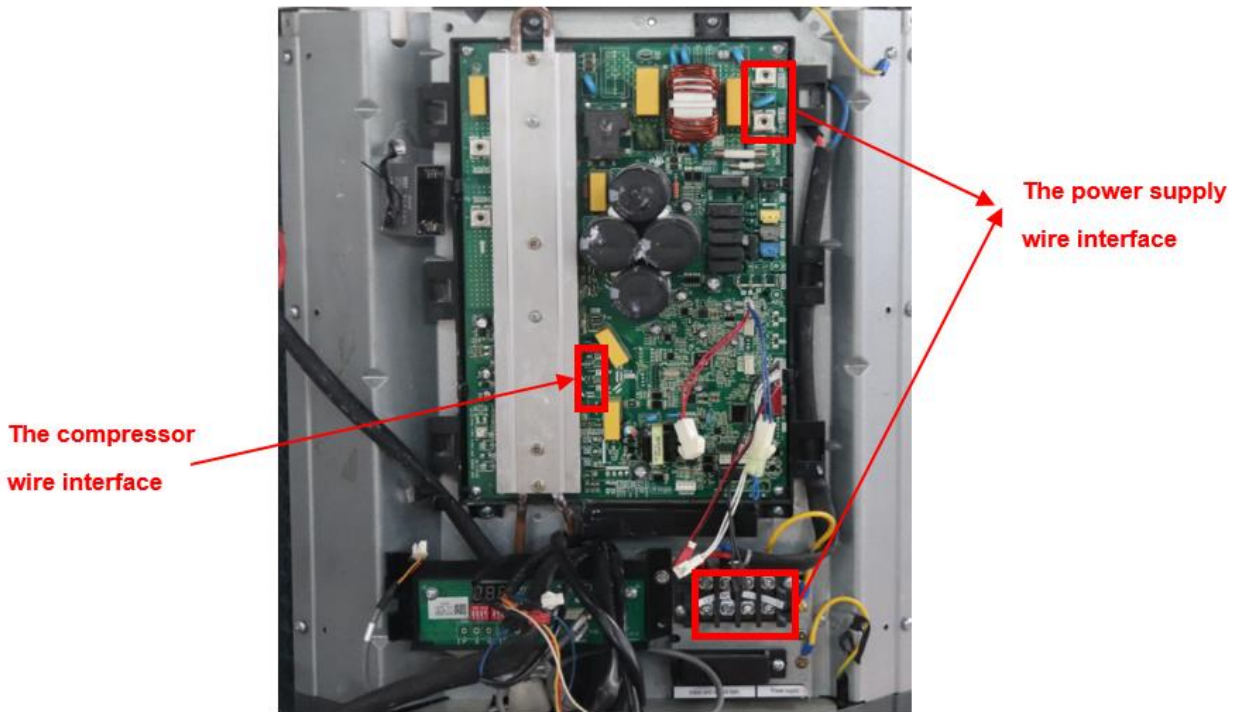
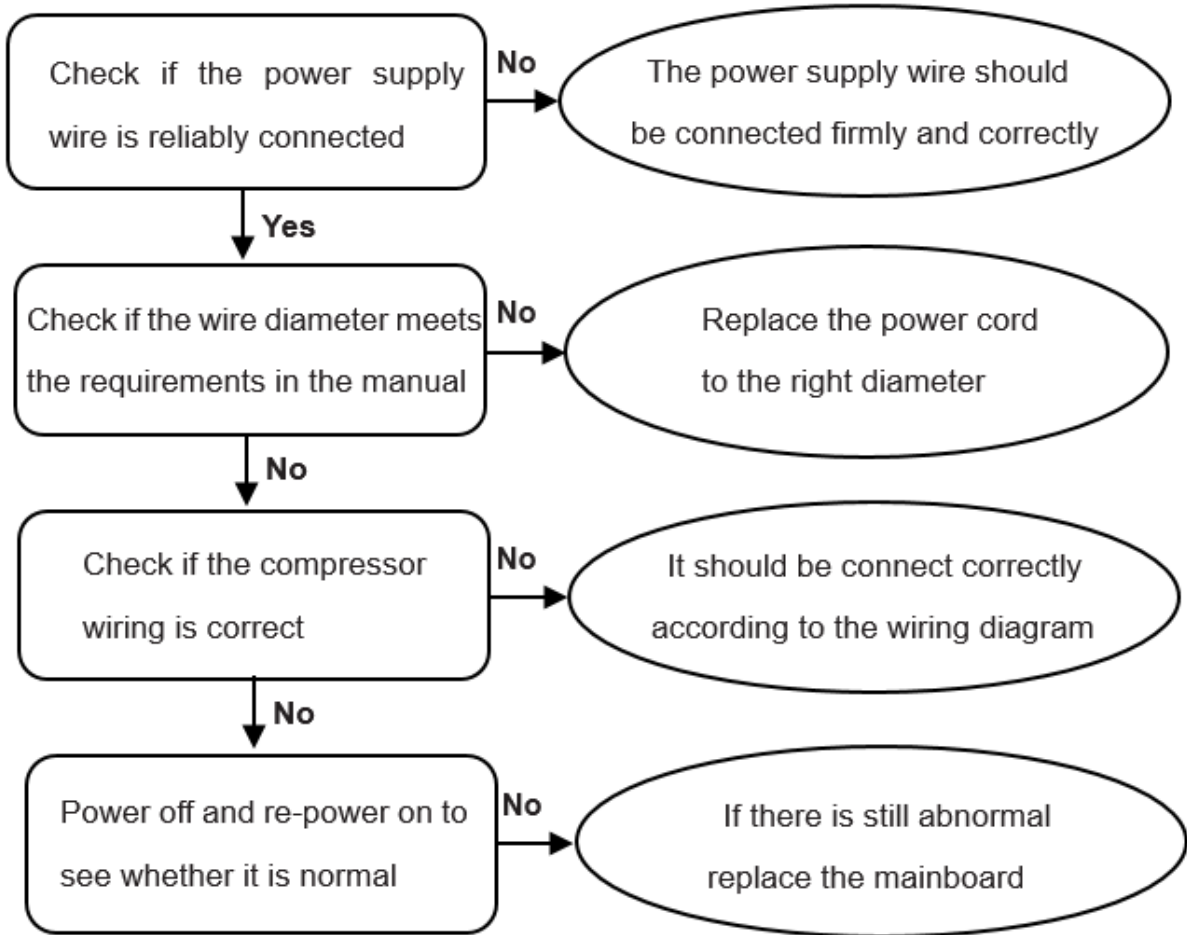

E10 (EEPROM failure)

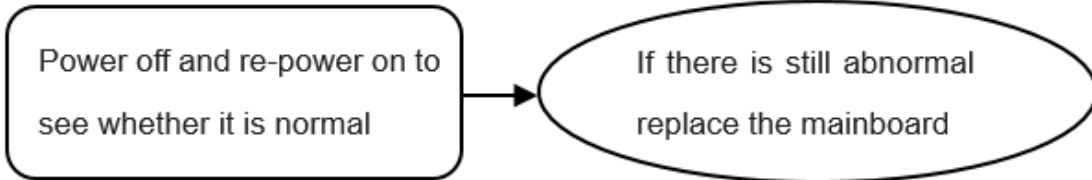

E12 (IPM modular sensor error)

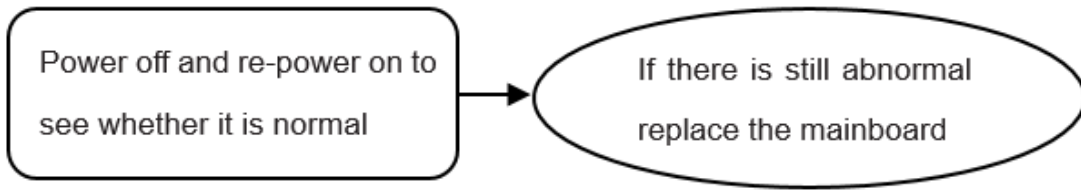

E13 (HLP Pressure sensor error)

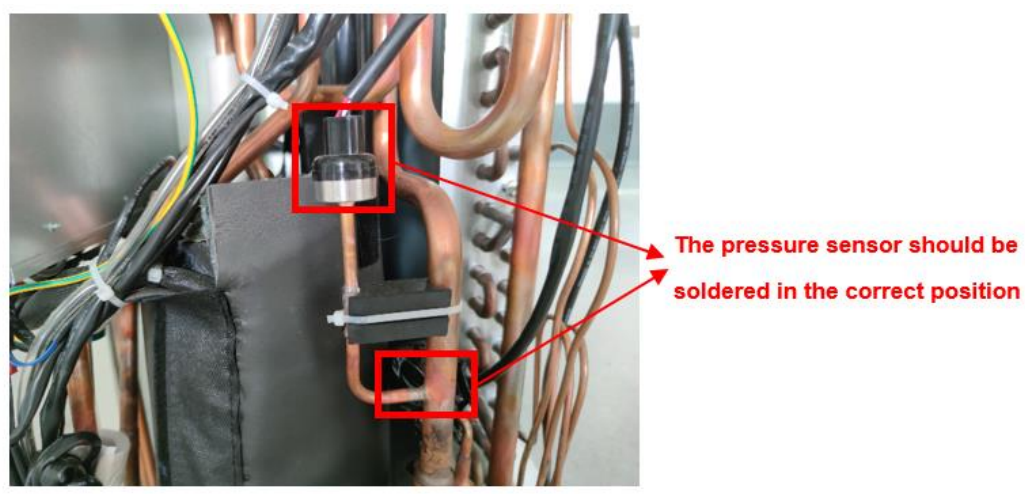
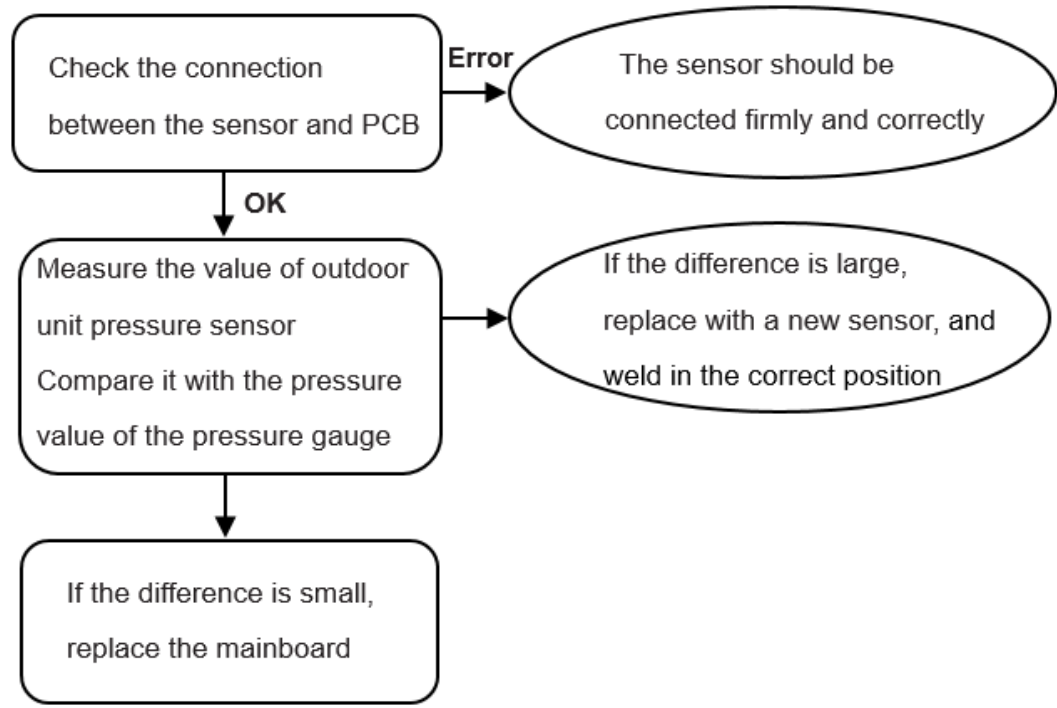

E14/H8/H12 (T3 or T5 sensor disconnect error)

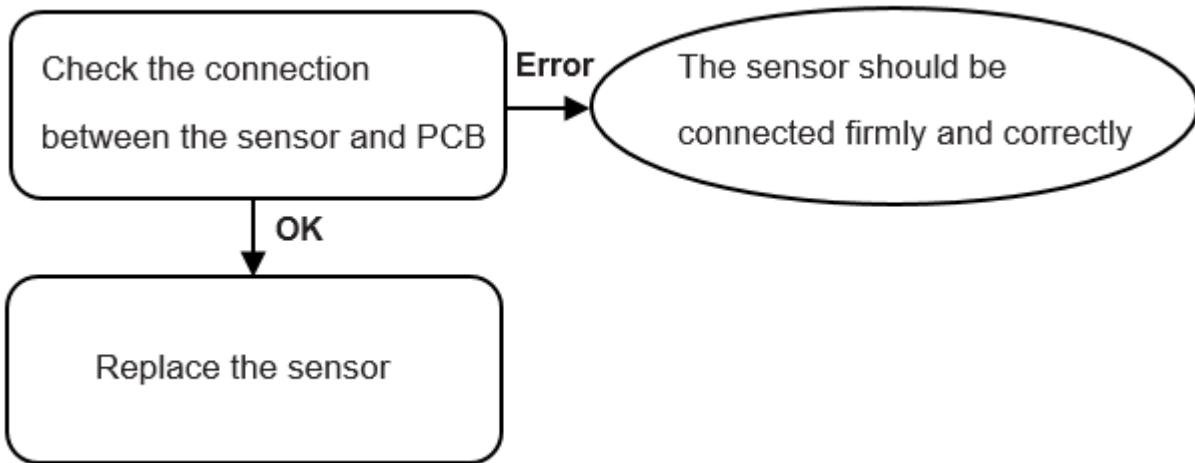

E15 (High pressure switch error)

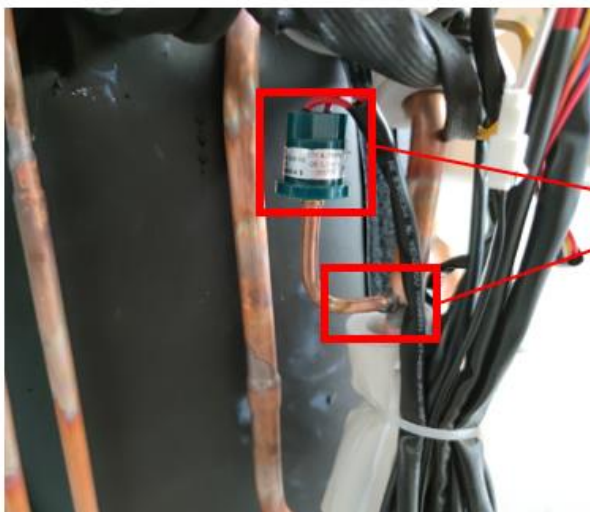
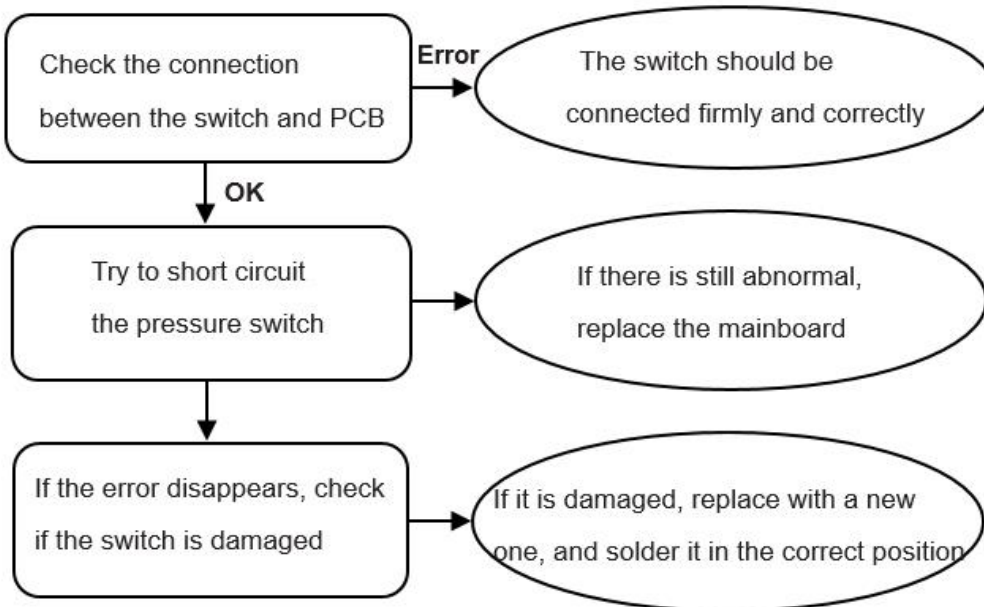

The high pressure switch should be soldered in the correct position

H0 (Communication error of main chip and IPM chip)

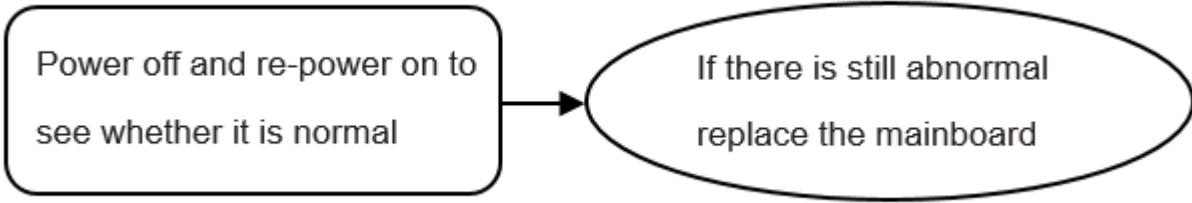

P1/H2 (High pressure switch protection)

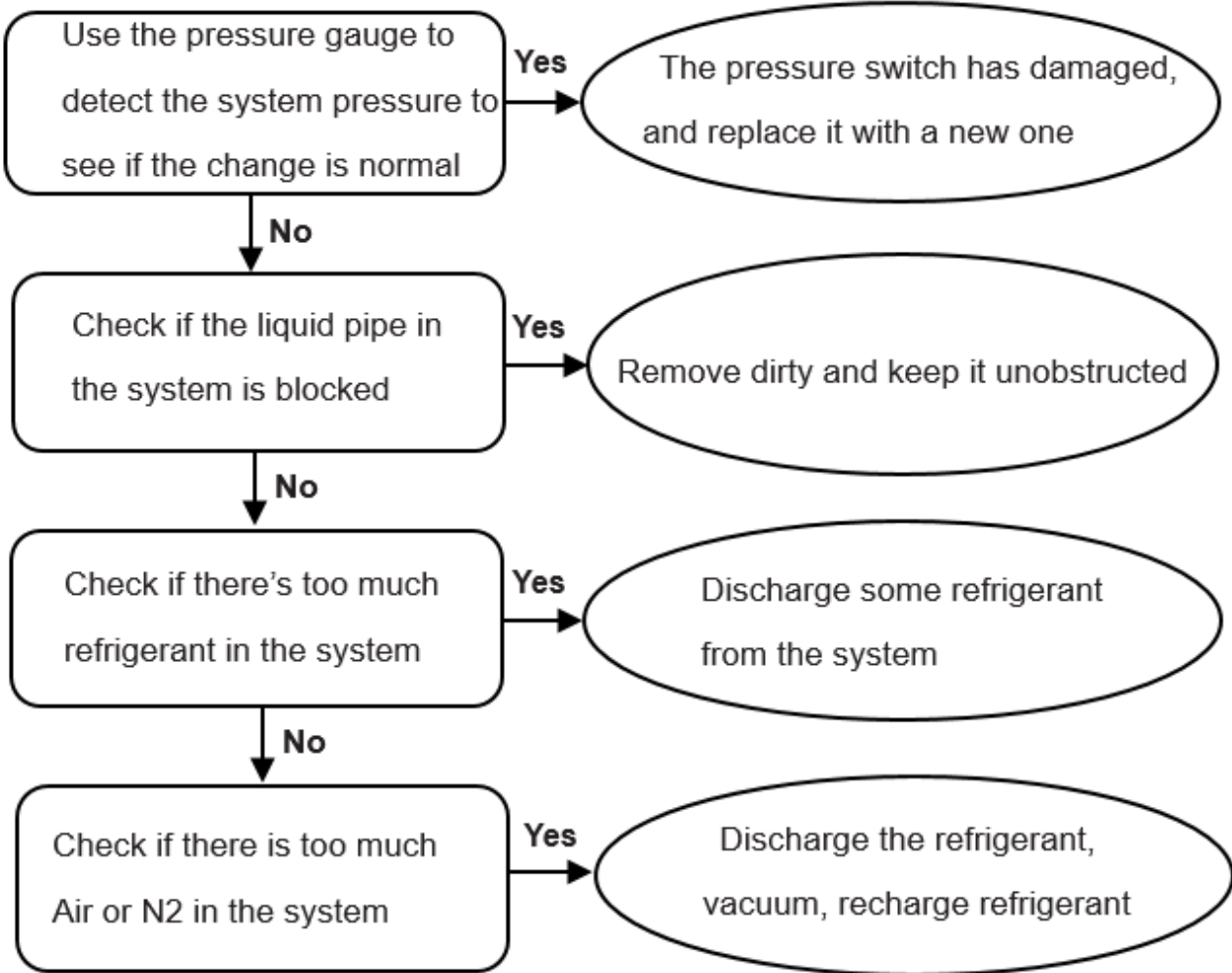

P2/H5 (Low pressure switch protection)

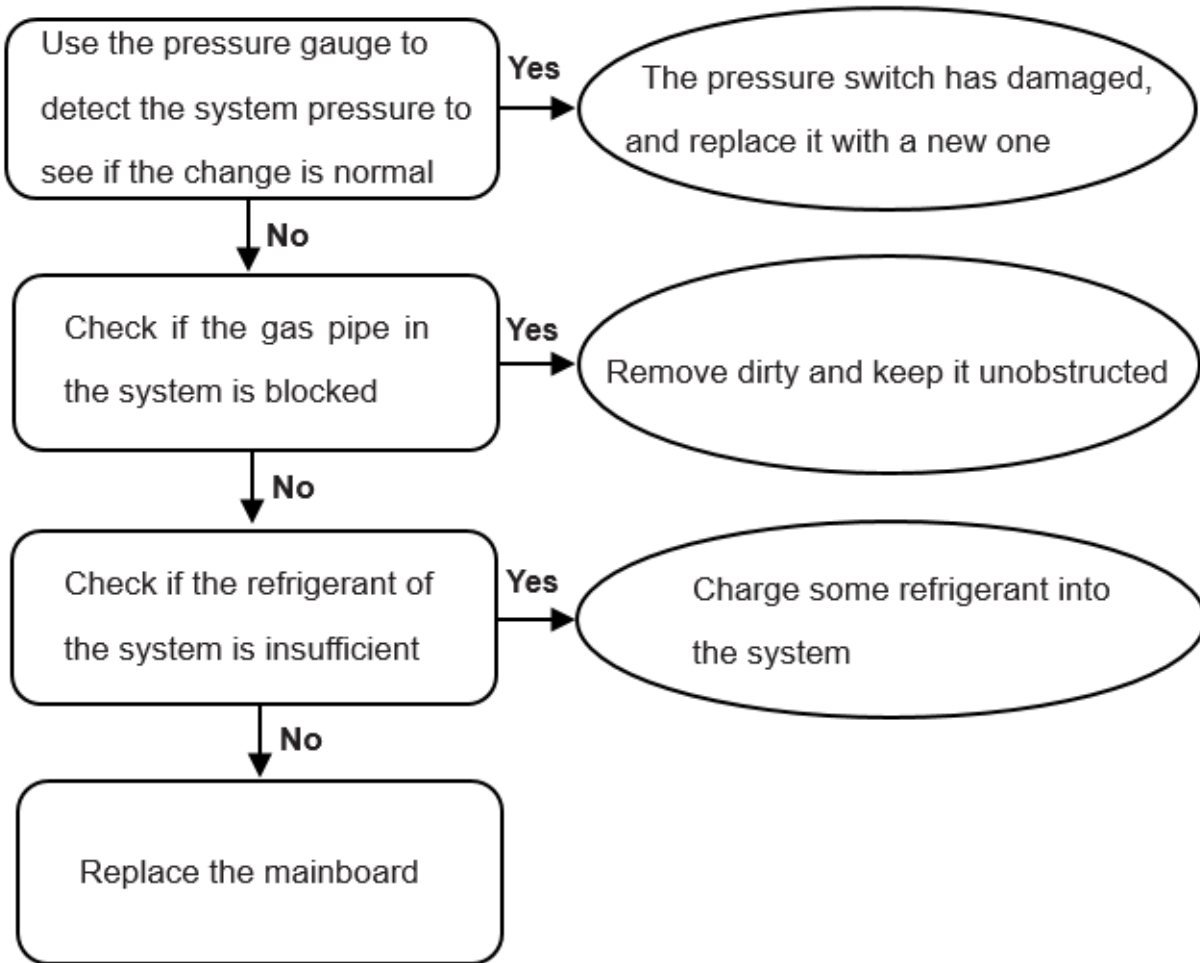

P3 (Inverter over current protection)

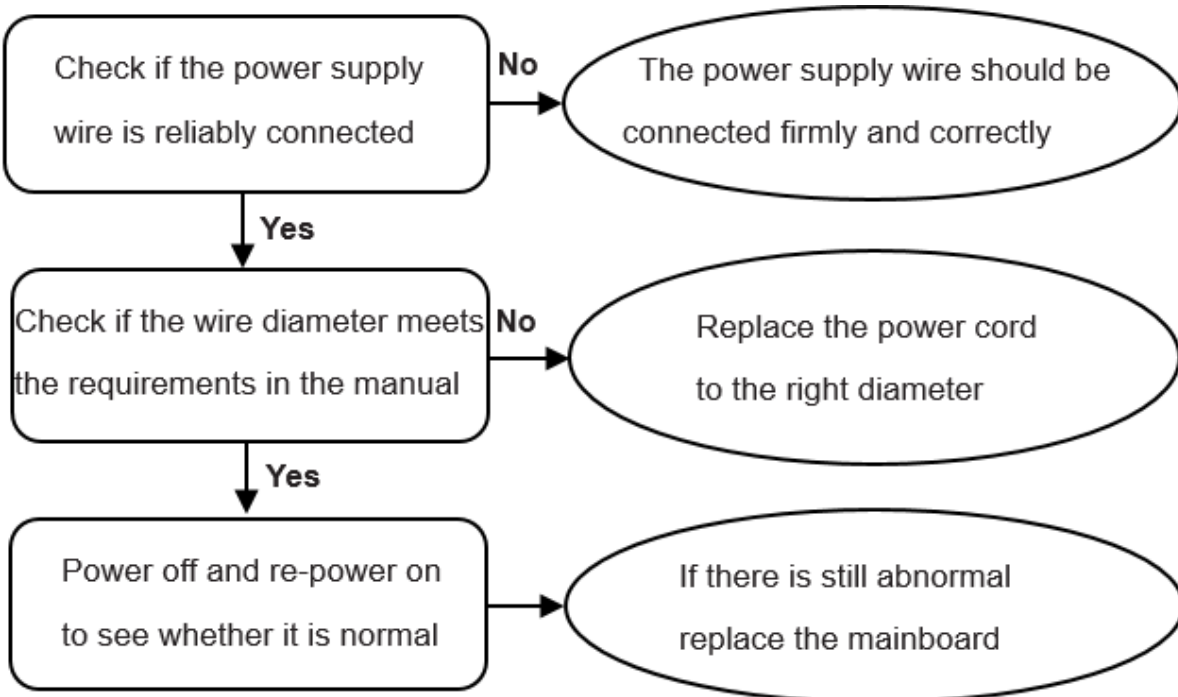

P4/H6 (T5 Discharge temperature abnormal error)

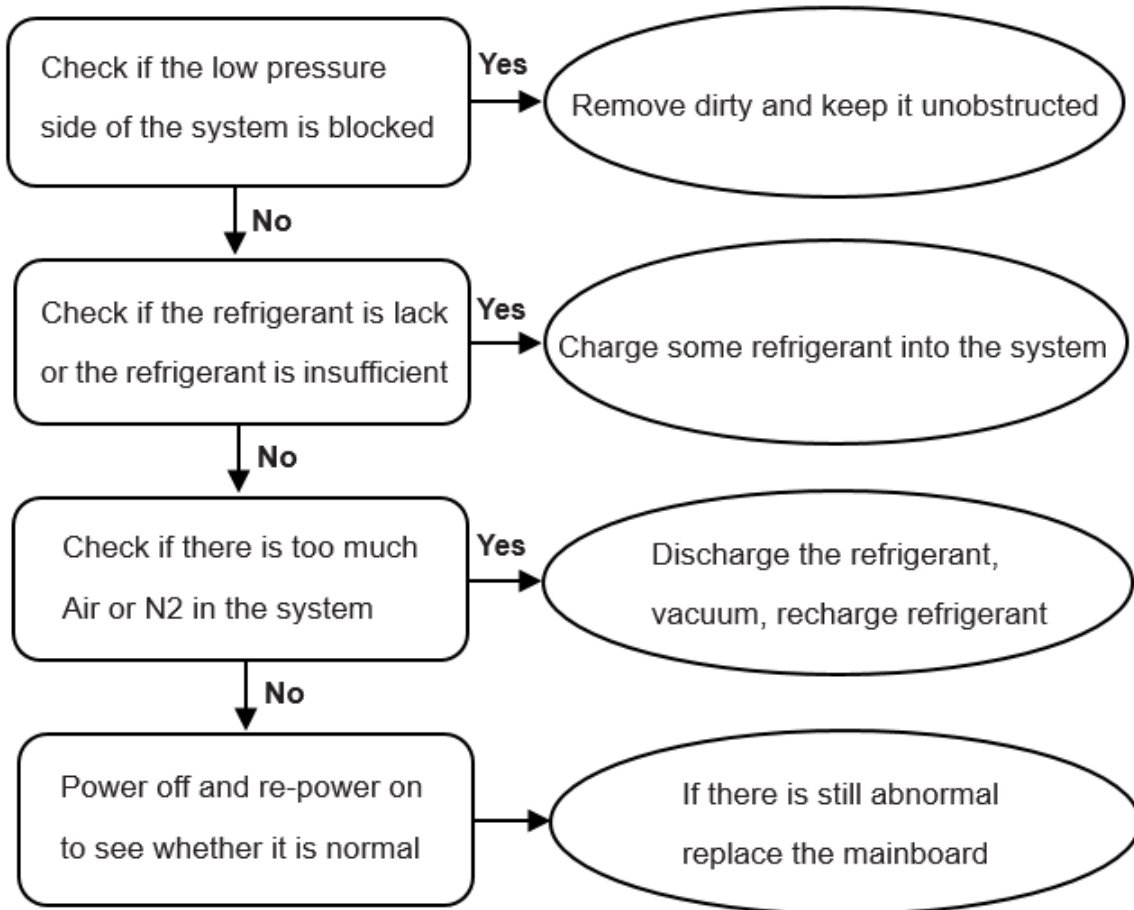

P5/H1 (T3 condenser sensor high temp protection)

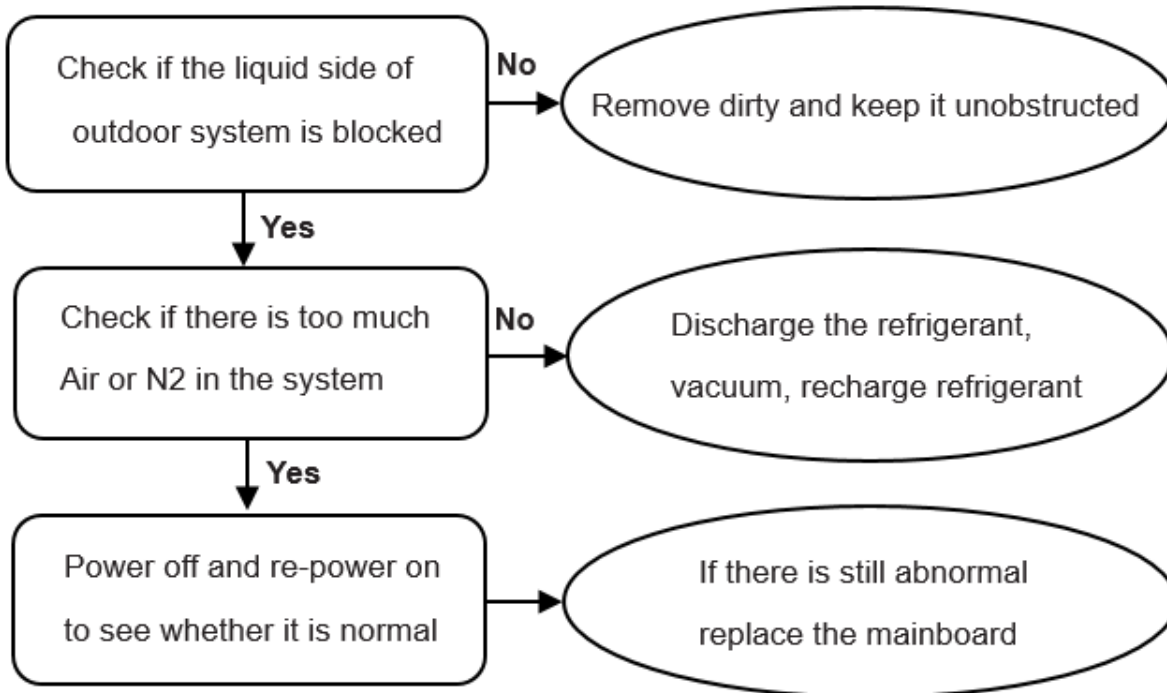

P6 (IPM module protection)

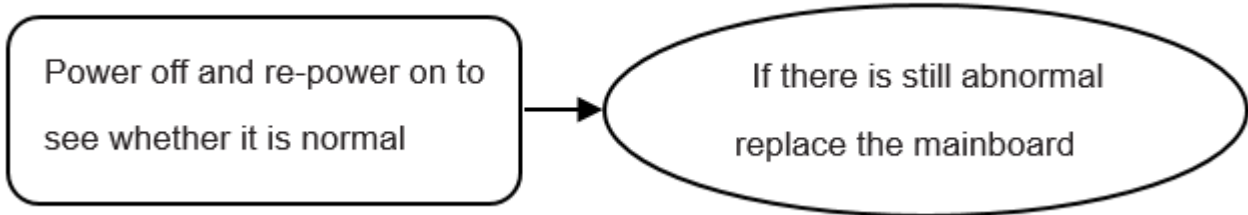

P8/H4 (IPM high temperature protection)

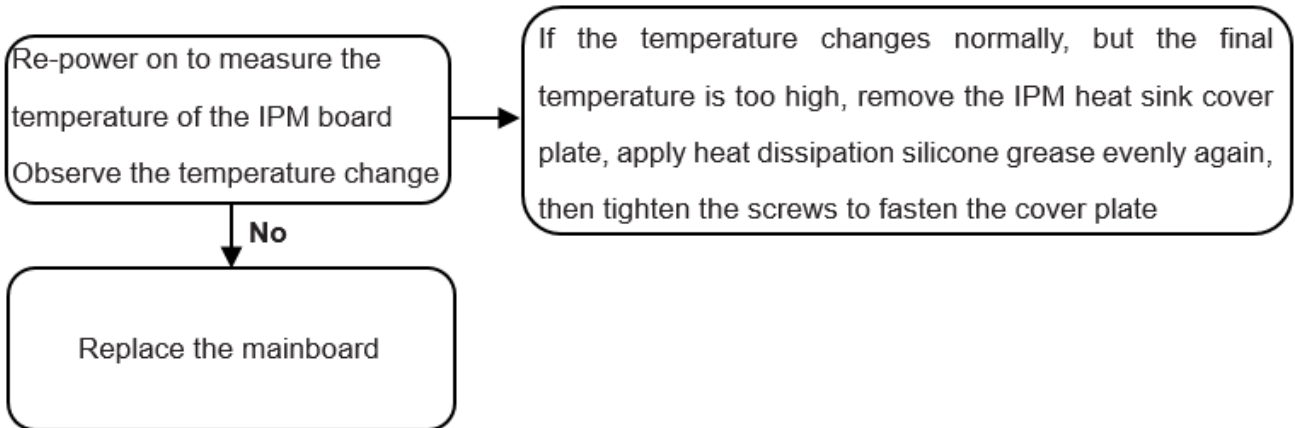

**IPM heat sink cover plate
should be fastened**



P9 (DC fan motor error)

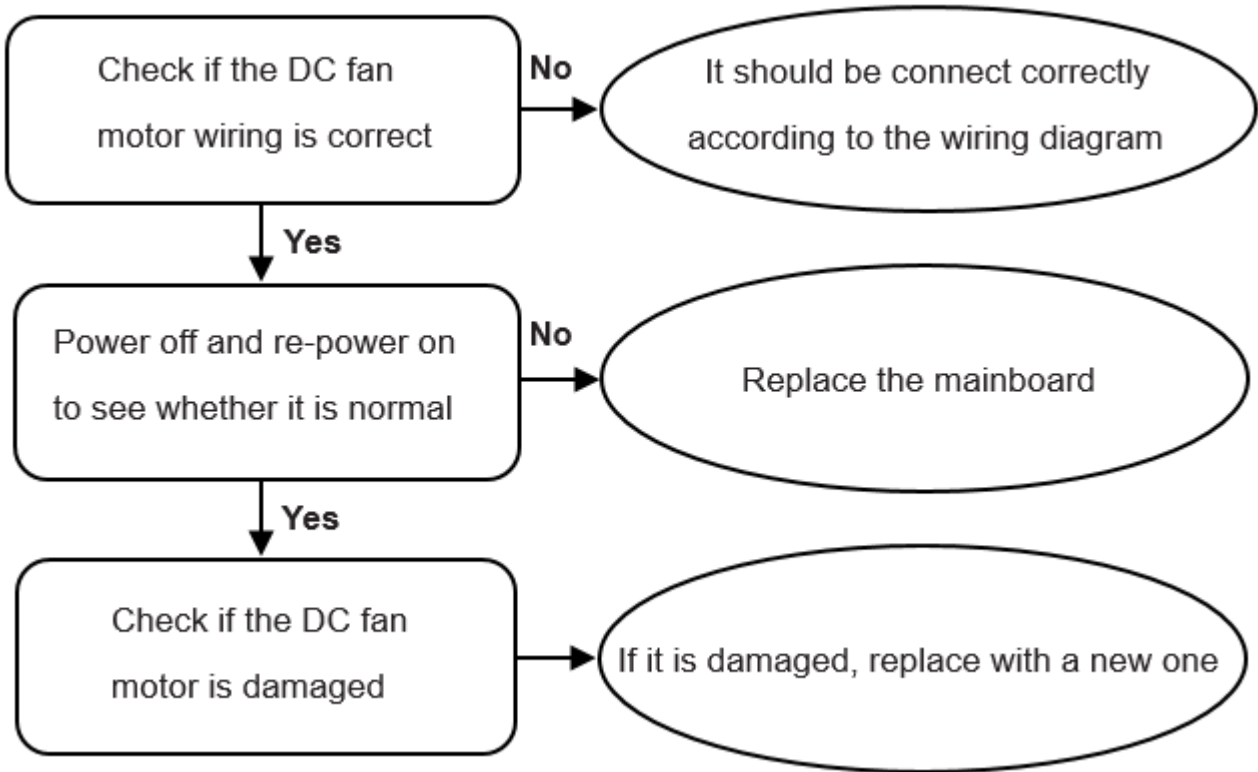

The DC fan motor wire interface

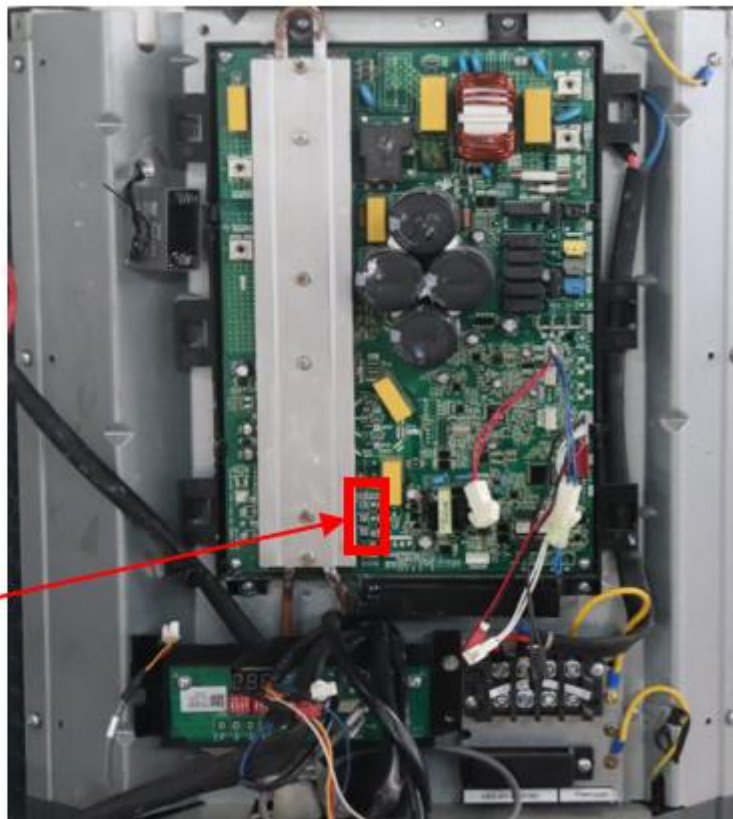

P12/H7 (Wet operation error)

Power off and re-power on to see whether it is normal

P13/H3(High pressure abnormal error-In heating mode)

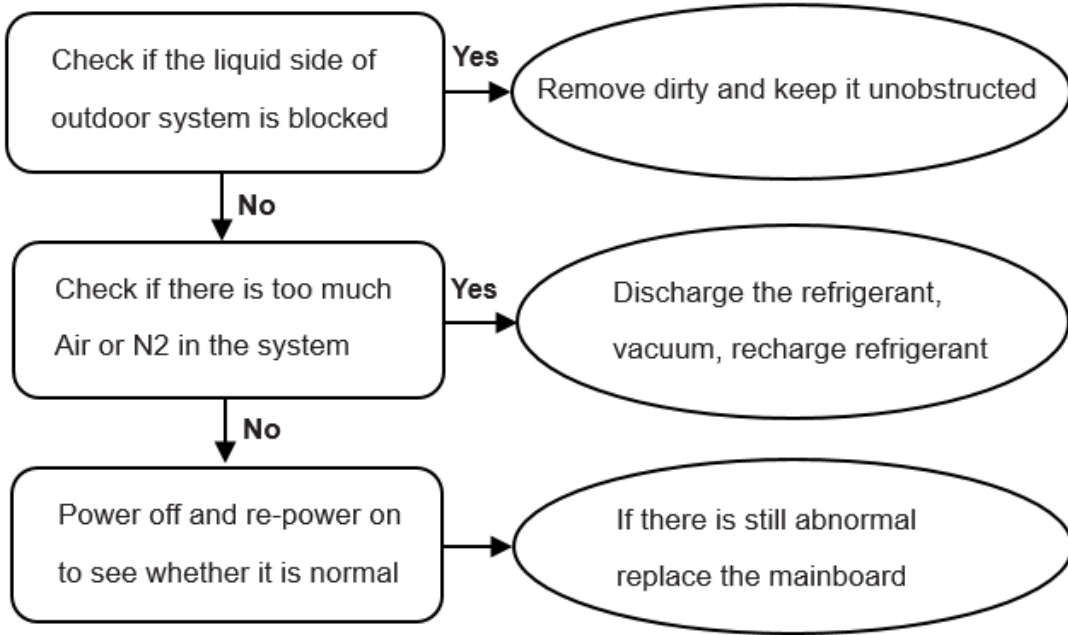

P14 (High compression ratio protection)

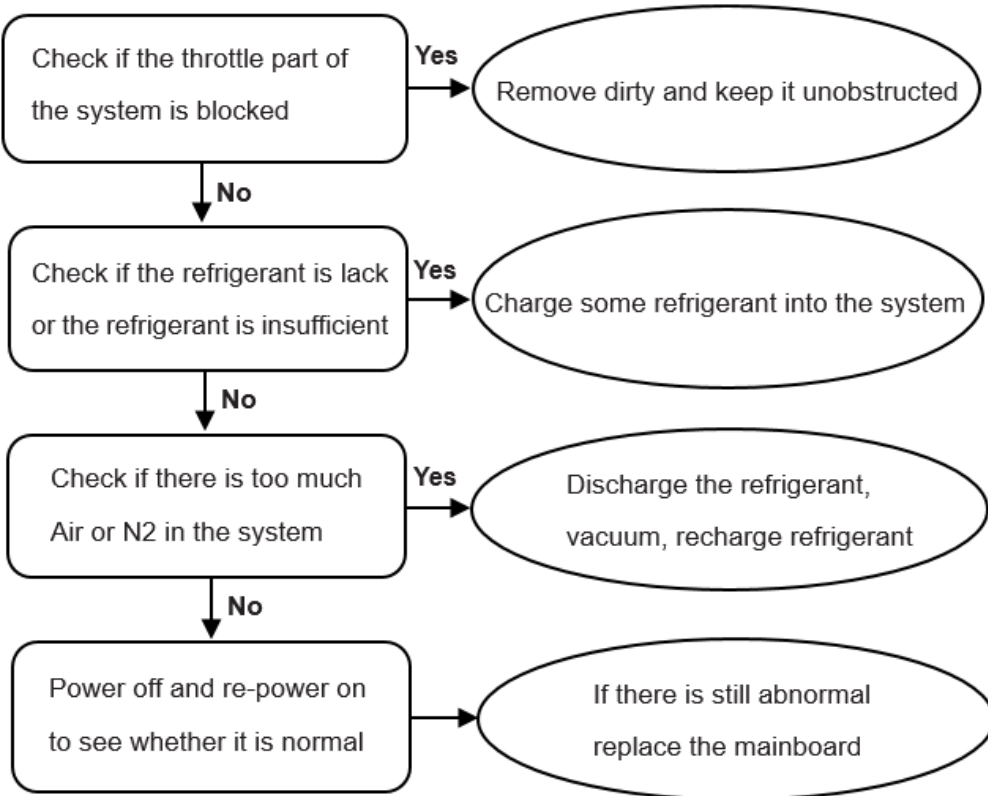

P15 (Low compression ratio protection)

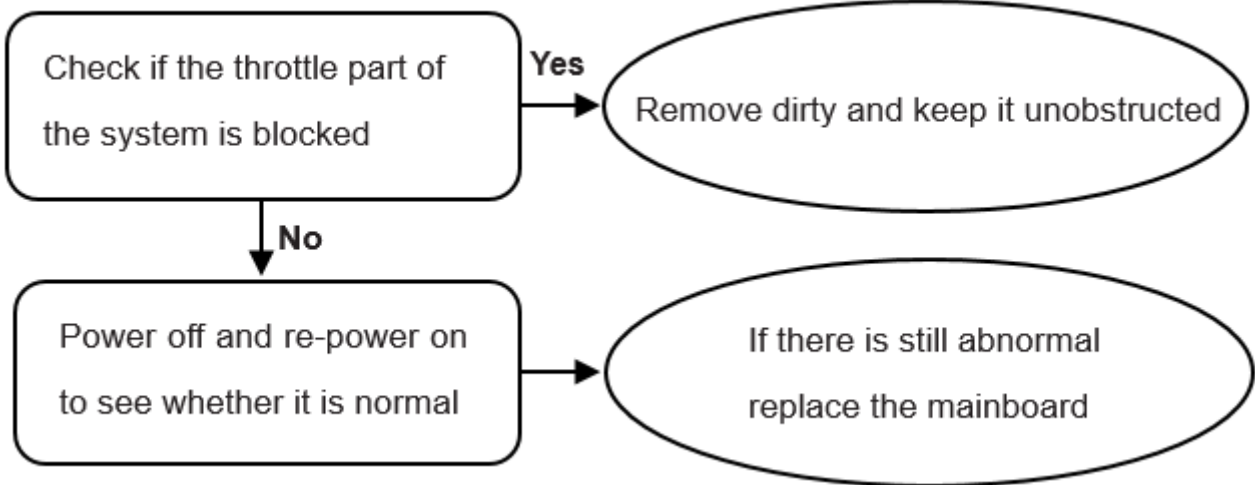

L1/L2(DC cable bus low/high voltage protection)

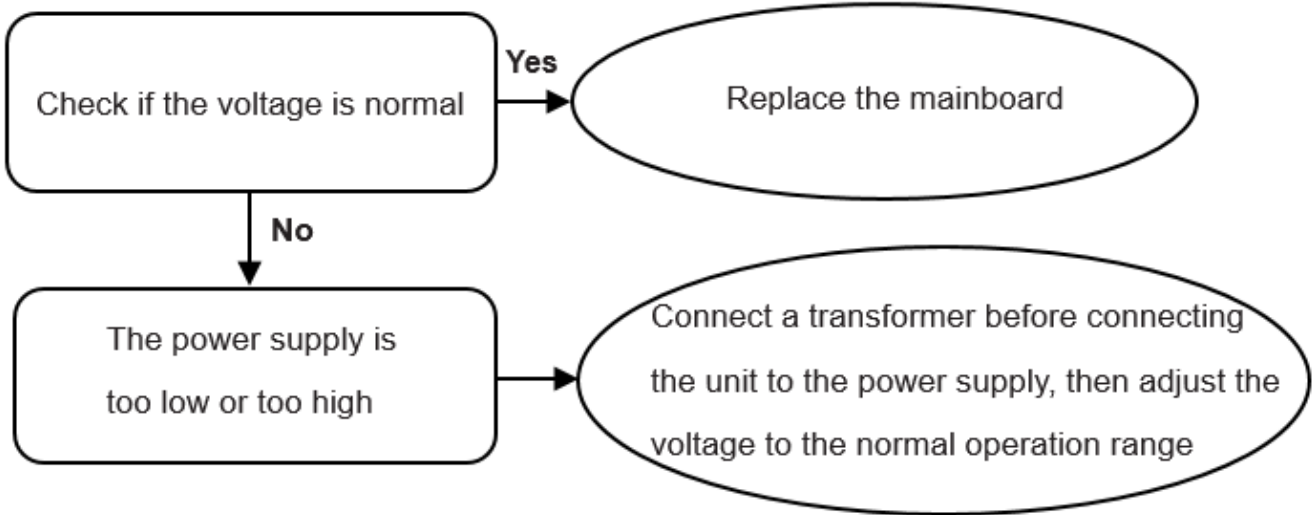

L4-L8 (IPM module subdivision protection)

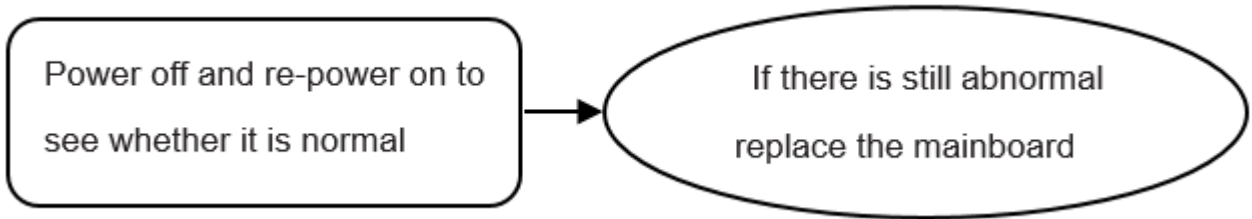

L9-LE (Frequency limitation protection, not error)

Part 4 Installation

1 .Precaution on Installation	47
2. Vacuum Dry and Leakage Checking	48
3. Additional Refrigerant Charge.....	50
4. Insulation Work.....	51
5. Test Operation	53

1. Precaution on Installation

1.1. Measure the necessary length of the connecting pipe, and make it by the following way.

- a. Connect the indoor unit at first, then the outdoor unit.
Bend the tubing in proper way. Do not harm them.

CAUTIONS:

- Daub the surfaces of the flare pipe and the joint nuts with frozen oil, and wrench it for 3~4 rounds
- With hands before fasten the flare nuts.

Be sure to use two wrenches simultaneously when you connect or disconnect the pipes.

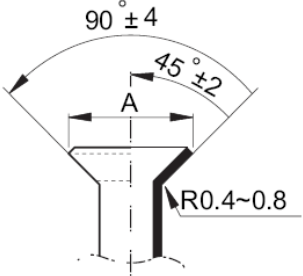
Pipe gauge	Tightening torque	Flare dimension A		Flare shape
		Min (mm)	Max	
Φ6.35	15~16N.m (153~163 kgf.cm)	8.3	8.7	
Φ9.52	25~26N.m (255~265kgf.cm)	12.0	12.4	
Φ12.7	35~36N.m (357~367kgf.cm)	15.4	15.8	
Φ15.9	45~47N.m (459~480 kgf.cm)	18.6	19.1	
Φ19.1	65~67N.m (663~684kgf.cm)	22.9	23.3	

- b. The stop value of the outdoor unit should be closed absolutely (as original state). Every time you connect it, first loosen the nuts at the part of stop value, then connect the flare pipe immediately (in 5 minutes). If the nuts have been loosened for a long time, dusts and other impurities may enter the pipe system and may cause malfunction later. So please expel the air out of the pipe with refrigerant before connection.
- c. Expel the air after connecting the refrigerant pipe with the indoor unit and the outdoor unit. Then fasten the nuts at the repair-points.

1.2. Locate The Pipe

- a. Drill a hole in the wall (suitable just for the size of the wall conduit), then set on the fittings such as the wall conduit and its cover.
- b. Bind the connecting pipe and the cables together tightly with binding tapes. Do not let air in, which will cause water leakage by condensation.
- c. Pass the bound connecting pipe through the wall conduit from outside. Be careful of the pipe allocation to do no damage to the tubing.

1.3. Connect the pipes.

1.4. Then, open the stem of stop values of the outdoor unit to make the refrigerant pipe connecting the indoor unit with the outdoor unit in fluent flow.

1.5. Be sure of no leakage by checking it with leak detector or soap water.

1.6. Cover the joint of the connecting pipe to the indoor unit with the soundproof / insulating sheath (fittings), and bind it well with the tapes to prevent leakage.

2. Vacuum Dry and Leakage Checking

2.1 Vacuum Dry: use vacuum pump to change the moisture (liquid) into steam (gas) in the pipe and discharge it out of the pipe to make the pipe dry. Under one atmospheric pressure, the boiling point of water (steam temperature) is 100°C. Use vacuum pump to make the pressure in the pipe near vacuum state, the boiling point of water falls relatively. When it falls under outdoor temperature, the moisture in the pipe will be vaporized.

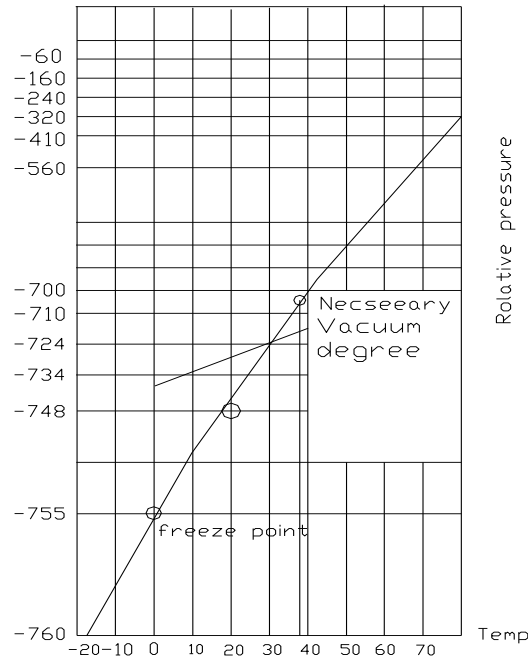

2.2 Vacuum dry procedure

There are two methods of vacuum dry due to different construction environment: common vacuum dry, special vacuum dry.

①. Common vacuum dry procedure

- Vacuum dry (for the first time)---connect the all-purpose detector to the inlet of liquid pipe and gas pipe, and run the vacuum pump more than two hours (the vacuum pump should be below -755mmHg)
- If the pump can't achieve below -755mmHg after pumping 2 hours, moisture or leakage point will still exist in the pipe. At this time, it should be pumped 1 hour more.
- If the pump can't achieve -755mmHg after pumping 3 hours, please check if there are some leakage points.
- Vacuum placement test: place 1 hour when it achieves -755mmHg, pass if the vacuum watch shows no rising. If it rises, it shows there's moisture or leakage point.
- Vacuuming from liquid pipe and gas pipe at the same time.
- Sketch map of common vacuum dry procedure.

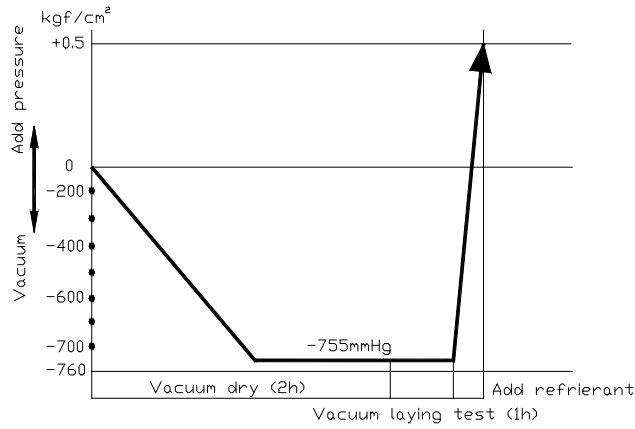

②. Special vacuum dry procedure

- This vacuum dry method is used in the following conditions:
- There's moisture when flushing the refrigerant pipe.
- Rainwater may enter into the pipe.
- Vacuum dry for the first time 2h pumping

③. Vacuum destroy for the second time Fill nitrogen to 0.5Kgf/cm²

Because nitrogen is for drying gas, it has vacuum drying effect during vacuum destroy. But if the moisture is too much, this method can't dry thoroughly. So, please pay more attention to prevent water entering and forming condensation water.

④. Vacuum dry for the second time 1h pumping

Determinant: Pass if achieving below -755mmHg. If -755mmHg can't be achieved in 2h, repeat procedure

③ and ④.

⑤. Vacuum placing test 1h

⑥. Sketch map of special vacuum dry procedure

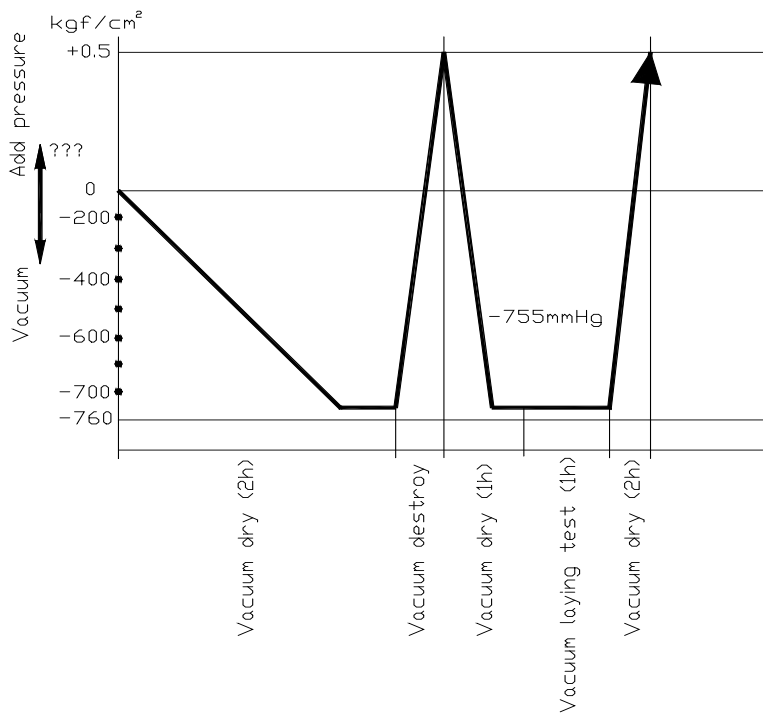

3. Additional Refrigerant Charge

Caution

- Refrigerant cannot be charged until field wiring has been completed.
- Refrigerant may only be charged after performing the leak test and the vacuum pumping.
- When charging a system, care shall be taken that its maximum permissible charge is never exceeded, in view of the danger of liquid hammer.
- Charging with an unsuitable substance may cause explosions and accidents, so always ensure that the appropriate refrigerant is charged.
- Refrigerant containers shall be opened slowly.
- Always use protective gloves and protect your eyes when charging refrigerant.

The outdoor unit is factory charged with refrigerant. Calculate the added refrigerant according to the diameter and the length of the liquid side pipe of the outdoor unit/indoor unit

R(g) \ D(mm)	$\phi 6.35$	$\Phi 9.52$	$\Phi 12.7$
L(m)			
Less than 5m (One-way)	—	—	—
Added Refrigerant When Over 5m(One-way)	$20g/m \times (L-5)$	$40g/m \times (L-5)$	$60g/m \times (L-5)$

Remark:

R (g): Additional refrigerant to be charged

L (m): The length of the refrigerant pipe (one-way)

D (mm): Liquid side piping

4. Insulation Work

4.1 Insulation material and thickness

4.1.1. Insulation material

Insulation material should adopt the material which is able to endure the pipe's temperature: no less than 70 °C in the high-pressure side, no less than 120 °C in the low-pressure side (For the cooling type machine, no requirements at the low-pressure side.)

- ◆ Example: Heat pump type----Heat-resistant Polyethylene foam (withstand above 120 °C)
Cooling only type----Polyethylene foam (withstand above 100 °C)

4.1.2. Thickness choice for insulation material

Insulation material thickness is as follows:

	Pipe diameter (mm)	Adiabatic material thickness
Refrigerant pipe	Φ6.4—Φ25.4	10mm
	Φ28.6—Φ38.1	15mm
Drainage pipe	Inner diameter Φ20—Φ32	6mm

4.2 Refrigerant pipe insulation

4.2.1. Work Procedure

- ① Before laying the pipes, the non-jointing parts and non-connection parts should be heat insulated.
- ② When the gas proof test is eligible, the jointing area, expanding area and the flange area should be heat insulated.

4.2.2. Insulation for non-jointing parts and non-connection parts

wrong	right	
Gas pipe and liquid pipe should not be put together to insulate	Insulate the gas pipe (cooling only)	Insulate the gas pipe and liquid pipe

18 SEER - Technical Manual

For construction convenience, before laying pipes, use insulation material to insulate the pipes to be deal with, at the same time, at two ends of the pipe, remain some length not to be insulated, in order to be welded and check the leakage after laying the pipes.

4.2.3. Insulate for the jointing area, expanding area and the flange area

- ① Insulate for the jointing area, expanding area and the flange area should be done after checking leakage of the pipes
- ② Make sure there's no clearance in the joining part of the accessorial insulation material and local preparative insulation material.

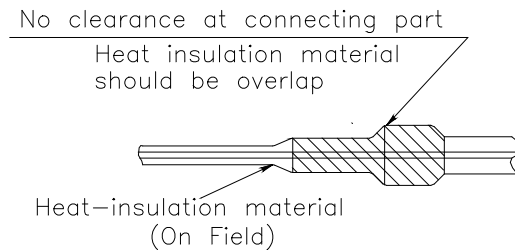

4.3 Drainage pipe insulation

The connection part should be insulated, or else water will be condensing at the non-insulation part.

4.4 Note

5.4.1 The jointing area, expanding area and the flange area should be heat insulated after passing the pressure test.

4.4.2 The gas and liquid pipe should be heat insulated individually, the connecting part should be heat insulated individually.

4.4.3 Use the attached heat-insulation material to insulate the pipe connections (pipes' tie-in ,expand nut) of the indoor unit.

5. Test Operation

(1) The test operation must be carried out after the entire installation has been completed.

(2) Please confirm the following points before the test operation.

- The indoor unit and outdoor unit are installed properly.
- Tubing and wiring are correctly completed.
- The refrigerant pipe system is leakage-checked.
- The drainage is unimpeded.
- The ground wiring is connected correctly.
- The length of the tubing and the added stow capacity of the refrigerant have been recorded.
- The power voltage fits the rated voltage of the air conditioner.
- There is no obstacle at the outlet and inlet of the outdoor and indoor units.
- The gas-side and liquid-side stop valves are both opened.
- The air conditioner is pre-heated by turning on the power.

(3) According to the user's requirement, install the remote controller when the remote controller's signal can reach the indoor unit smoothly.

(4) Test operation

Set the air conditioner under the mode of "COOLING" with the remote controller, and check the following points.

Indoor unit

- Whether the switch on the remote controller works well.
- Whether the buttons on the remote controller works well.
- Whether the air flow louver moves normally.
- Whether the room temperature is adjusted well.
- Whether the indicator lights normally.
- Whether the temporary buttons works well.
- Whether the drainage is normal.
- Whether there is vibration or abnormal noise during operation.

Outdoor unit

- Whether there is vibration or abnormal noise during operation.
- Whether the generated wind, noise, or condensed of by the air conditioner have influenced your neighborhood.
- Whether any of the refrigerant is leaked.



OMEGA
ENVIRONMENTAL
TECHNOLOGIES LLC.

17702 Mitchell North, #101
Irvine, CA. 92614 .USA
Tel: 714 795 2830
Fax: 714 966 1646
info@omegavrf.com
www.otecomega.com

OTECTM
AIR CONDITIONING

Showroom & Technology Center
11380 Interchange Circle North
Miramar, FL 33025 .USA
Tel: 305 901 1270
Fax: 954 212 8280
info@omegavrf.com
www.otecomega.com

ICVC8N(H)0(2)A-TM1G0822